

# Multidimensional Pilot Crew State Inference for Improved Pilot Crew-Automation Partnership

Stefan Suck and Florian Fortmann

OFFIS - Institute for Information Technology

Oldenburg, Germany

Email: stefan.suck, florian.fortmann@offis.de

**Abstract**—Automation is a substantial technology of modern aircraft. Even though automation has significantly improved aviation safety, insufficient partnership between the pilot crew and the automation, and confusion over the status of the automation is still a problem. The European project A-PiMod addresses these problems by developing a virtual crew member, which takes the position of classical aircraft automation. As part of the crew, the virtual crew member must be able to anticipate the internal states of the human crew members. This ability helps, e.g., to improve the task share in the cockpit by means of dynamic adaptations of task distributions. In this paper, we present the concept of the A-PiMod pilot model, which will be used for inferring the internal state of the human crew members. The internal state is composed of different sub-states, which have been defined during the initial phase of the project. The addressed sub-states are situation awareness, workload, and intentions. The target states will be inferred based on real-time data about the mission, tasks, and pilot behaviors, including what they say, where they look at, and how they act.

**Keywords**—Human-Machine Cooperation; Cognitive Model; Aircraft Crew.

## I. INTRODUCTION

Automation is a substantial technology of modern aircraft [1]. Automation accomplishes (partially or fully) a task that was previously carried out (partially or fully) by a human operator [2]. Overall, automation has significantly improved aviation safety [3]. However, after many years of automation it turned out that this technology is like a two-edged sword. It has been shown that there are several pitfalls associated with automation [4], such as insufficient partnership between the pilot crew and the automation, and confusion over the status of the automation. These pitfalls refer, e.g., to the lack of communicating internal states, including the situational picture and the intents of the pilot crew and the automation. Insufficient partnership between the pilot crew and the automation has led to several accidents in the past. A well-studied example is the crash of China Airlines Flight 140, which can be attributed to conflicting intentions [5] between the pilot crew and the automation.

The European project Applying Pilot Models for Safer Aircraft (A-PiMod) [6] addresses two major issues of the aviation domain: (1) poor pilot crew-automation partnership, and (2) confusion over the status of automation. As introduced above, both issues are highly connected to each other. In order to tackle these issues, the project aims to develop a virtual crew member, which takes the position of classical aircraft automation. The virtual crew member should perfectly integrate into the pilot crew resulting in a cooperative human-machine cockpit crew. As part of the crew, the virtual crew member must be able to anticipate the internal states of the

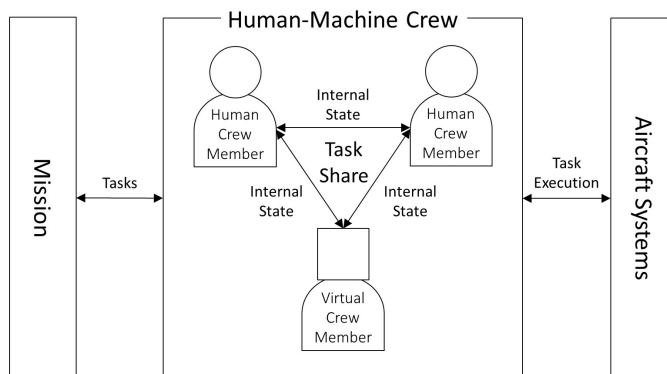

Figure 1: Partnership in the aircraft cockpit between human crew members and a virtual crew member.

human crew members, as well as the human crew members must be able to anticipate the internal states of the human and virtual crew members. This ability helps, e.g., to improve the task share in the cockpit by means of dynamic adaptations of task distributions. The concept underlying the A-PiMod project is sketched in Figure 1. A mission is achieved cooperatively by sharing tasks according to the individual capabilities of each crew member. The basis of good partnership is a sufficient understanding of each crew member about the internal states of the other crew members.

In this paper, we present the concept of the A-PiMod pilot model, which will be used for inferring the internal state of the human crew members. The concept of our pilot model combines cognitive and probabilistic modelling approaches. The internal state is composed of different sub-states, which have been defined during the initial phase of the project. The addressed sub-states are situation awareness, workload, and intentions. The sub-states will be inferred based on real-time data about the mission, tasks, and pilot behaviors, including what they say, where they look at, and how they act.

In Section II, a short overview of cognitive and probabilistic operator models and some of their applications is given. Section III introduces the pilot model and describes the different target states. The integration into the A-PiMod architecture and the interaction with other A-PiMod components is explained in Section IV. Section V concludes and reveals future steps.

## II. RELATED WORK

There is a great effort within the human modelling community to develop operator models to support the development of complex human-machine systems. The technology underlying

these models is as diverse as the purpose of using them. The A-PiMod pilot model combines cognitive and probabilistic modelling approaches. For this reason, we provide an overview of these modelling approaches in this section.

#### A. Cognitive Models

Cognitive models are intended to describe mental processes of human agents. An overview of extant cognitive computational models is provided in [7]–[11]. Cognitive models describes cognitive processes like human perception, decision making, memory and learning processes. When cognitive models are implemented in software, they can be used to simulate human behavior and to predict human error. For example, these cognitive architectures can be used to support the development of user interfaces in early design phases. A cognitive architecture can be understood as a generic interpreter that executes formalized task models in a psychological plausible way.

Cognitive architectures were established in the early eighties as research tools to unify psychological models of particular cognitive processes [12]. The most noted cognitive architectures are Adaptive control of Thought Rational (ACT-R) [13][14], State Operator Apply Result (SOAR) [15][16] and Man-Machine Integration Design and Analysis System (MIDAS) [17][18]. These early models only dealt with laboratory tasks in non-dynamic environments [19][20]. Furthermore, they neglected processes such as multitasking, perception and motor control that are essential for simulating human-machine interaction in highly dynamic environments. Models such as ACT-R and SOAR have been extended in this direction [21][22] but still have their main focus on processes suitable for static, non-interruptive environments. Other cognitive models like MIDAS [23], Architecture for Procedure Execution (APEX) [24] and Cognitive Network of Tasks (COGNET) [25] were explicitly motivated by the needs of human-machine interaction and thus focused for example on multitasking right from the beginning. The cognitive architecture Cognitive Architecture for Safety Critical Task Simulation (CASCaS) was developed by [26] and recognized by [27] as one of the best in the world. CASCaS has been applied in several projects, in order to analyse perception [28], attention allocation [10][29], decision making [26], and error [26][30] of humans in the automotive and aviation domains.

#### B. Probabilistic Models

While cognitive architectures are usually based on rules (CASCaS) or semantic networks (MIDAS) other approaches utilize probabilistic methods to model human operators. In [31] the author employs Hidden Markov Models (HMM), to describe the instrument scanning behaviour of aircraft pilots. In [32] HMMs are used to infer on the behaviour of operators of unmanned aerial vehicles and the currently performed task by monitoring operators' interactions with a User Interface.

In the automotive domain, there are approaches which employ probabilistic driver models. In [33], a hierarchical structure of Dynamic Bayesian Networks (DBN) is used to generate driving behaviours and actions from driving goals. It is also shown that it is possible to derive the behaviours and driving manoeuvres of the driver from his actions. Another example for the inference and classification of driving behaviours can be found in [34]. In the domain of Intention Recognition Systems, DBNs are used to determine the intentions of drivers

[35] and to infer the intent of software users to provide specific help [36].

#### C. Related Applications

The pilot model used in the Crew Assistant Military Aircraft (CAMA) consists of a petri-net based part to model the normative pilot behaviour and a adaptive part which is based on fuzzy rules [37]. The adaptive part determines if deviations from the normative model are errors or were intended by the pilot due to, e.g., high workload.

Cognition Monitor (COGMON) [38] is a multidimensional approach to provide information about the state of a aircraft pilot. It relies on subjective, contextual, behavioural and physiological measures. However, to collect the physiological data intrusive techniques like electroencephalography are used, which we aim to avoid in A-PiMod.

### III. CREW STATE INFERENCE

Knowledge about the cognitive pilot crew state provides the possibility of adapting the systems state accordingly. The cognitive pilot crew state cannot be estimated as a whole. Instead, the cognitive pilot crew state has to be decomposed into target states which will be estimated. In the past, there has been research on a broad range of target states, such as situation awareness [39][40] and workload [41][42]. Although there may be more target states it turned out, during the requirements engineering phase of A-PiMod that the Crew State Inference (CSI) will be focused on the following target states:

- Intentions: Does the pilot intend to perform the tasks he is assigned to or is he intending to do something different?
- Workload: In how far is the pilot cognitively and physically used to capacity?
- Situation awareness: Is the pilot aware of the things around him that are of interest in context of the flight task?

For the acquisition of the necessary data for the defined target states, the Crew State Inference relies on non-intrusive techniques. The CSI infers the state of every human crew member separately. The intention is the first target state to be estimated. The results of the intention recognition are also used as inputs for the assessment of the situation awareness.

#### A. Intention

The A-PiMod architecture provides adaptiveness in the manner of automation and crew-automation interaction. To realize this adaptiveness the automation needs information about when to provide assistance or when it is necessary to interfere. To determine this, it is desirable for the system to know the pilot's intention. If the intention is not consistent with the situation known to the system, which could lead to a critical situation, there would be a need for further interaction with the crew.

In [43], intention is described as a composite concept specifying what the agent has chosen and how the agent is committed to that choice. The agent from this statement can be a pilot and his choice refers to a goal. This reflects that the pilot's intentions are strongly connected to the goal he is actually trying to achieve. As already mentioned, the agent

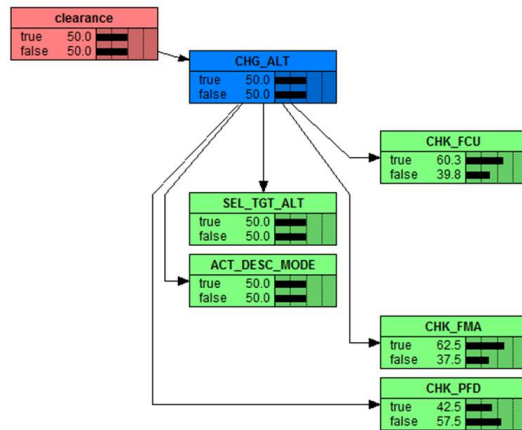

Figure 2: Basic Bayesian Network for a change altitude task

needs to be committed to this goal. That means that the agent must be able to take part in a plan, which is needed to achieve the goal. A plan is mainly a certain behaviour, which is a sequence of observable actions, that leads to the achievement of a specific goal. Plans can be more or less complex. Complex plans usually can be separated into sub-plans. Thus, the complex plans become goals of their sub-plans. In the literature the intention recognition becomes plan recognition in this case. The tasks of a pilot also serve the achievement of a goal. Complex task can be separated into sub-tasks and can become the goals of their sub-task, too. So, a task of a pilot can be interpreted as equivalent to a plan or a goal. To execute a task, a pilot has to show a specific behaviour which consists of certain actions. This means that, for each task, there exists some set of actions which is typical for this task. Many of these actions can be observed, e.g., interactions with the conventional cockpit interfaces or touch displays, or the gaze on instruments. On the basis of these observations the CSI Intention module infers on the tasks which are currently performed by the pilot. For the task inference, a Bayesian network is used. A basic example for the task to change the altitude is shown in Figure 2. The depicted network is a segment of the currently implemented network. The nodes in the network can be, depending on the type of information they represent, divided into the following groups: task nodes, context observation nodes, and action nodes. The node *CHG\_ALT* represents the task, the node *clearance* is a general observation of the context and represents the availability of a clearance from Air Traffic Control (ATC) for an altitude change. Context information can make the inference more robust if the action patterns of tasks are very similar. The nodes *SEL\_TGT\_ALT* and *ACT\_DESC\_MODE* are actions and represent interactions with the Flight Control Unit (FCU). *CHK\_FCU*, *CHK\_PFD* and *CHK\_FMA* are also actions and represent if the pilot has looked, e.g., at the FCU. Every network node has a probability table which quantifies the influence of the parent nodes on the current node. For nodes without parents (no incoming edges) a-priori probabilities have to be defined. If an action is performed, its corresponding node gains the state *true*, this results in an increasing probability of all tasks that can cause

this action. The Bayesian network is currently constructed manually. The structure is based on a task analysis which was made in advance. The necessary parameter values for these probability tables are currently chosen on the basis of this task analysis. These values will be revised on the basis of the data which will be collected during simulator experiments. The intention inference delivers for each task node a probability value that this task is currently being executed by the currently considered pilot. The tasks with a probability value above a certain threshold are interpreted as the currently executed tasks of the pilot. These are the subjective tasks of a pilot, which are the output of the intention inference module. Thanks to this approach based on a Bayesian network, we will be in the position to recognize the pilot's intentions seen as goals or tasks.

### B. Workload

High, as well as too low workload can influence the pilots' performance negatively. Thus, the purpose of the workload module is to determine in how far the pilot is cognitively and physically used to capacity. In this module the workload, of a pilot is described by a multi-resource model which is comparable to the one of Wickens [44]. The dimensions of our workload model are Visual perception, Visual processing, Auditory perception, Auditory processing, and Auditory action. According to this model the pilots' cognitive and physical capacities in the different dimensions are limited. The execution of tasks causes the consumption of some of these capacities, which leads to an increased workload. The relevant tasks were identified and described during a task analysis. The description of every identified task is stored in a task pool. The task description contains, among other things, information about the workload which is created by a task in the different dimension. These workload values were collected by interviewing pilots with a questionnaire. To estimate the current workload of the pilot, his objective tasks, the tasks he is currently assigned to are taken into account. The workload values stored in the task descriptions for each dimension are summed up over the pilot's objective tasks. These aggregated workload scores reflect the actual load of the pilot in the different dimensions and are the output of the workload module.

### C. Situation Awareness

Situation awareness (SA) is a state of knowledge which is the product of a cognitive process, called situation assessment. During situation assessment, operators interpret available environment and system information in the context of their current goals. Based on SA, operators decide what they are going to do in a certain situation. Due to high automation, loss of SA can remain without bad consequences in standard situations but can lead to accidents in critical situations. Knowing the current coverage of SA at each moment in time during operation could help to prevent incidents and accidents caused by incorrect SA. The purpose of the SA module of the CSI is real-time SA inference. The basis for the inference process is a formal situation model and a formal model of SA which represents the human operators subjective state. Both models consist of a set of atomic elements. These elements can refer to basic items like information or more complex things like tasks. Information elements are linked to the perception level of the SA while the tasks are more related to the comprehension level.

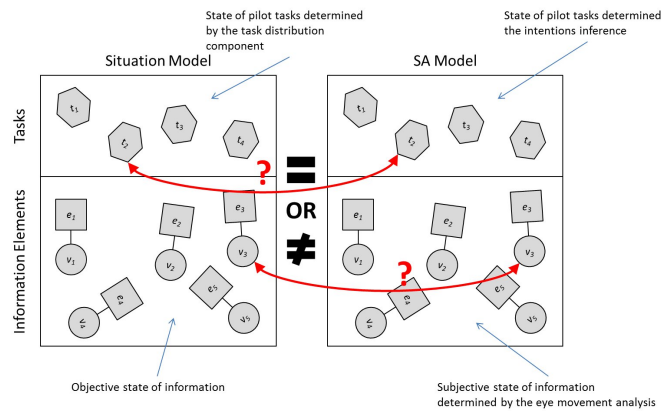

Figure 3: Description of SA inference for perceptual aspects

The human operator can update the subjective model by, e.g., focusing on sources of information. The state of each atomic element of the SA model can be compared to the state of each element of the situation model. The approach is visualized in Figure 3. The comparison allows detecting inconsistencies between the real situations and situations as they are perceived by the operator. Currently, SA is focused on the tasks of a human operator. The tasks of the Situation Model are the objective tasks of the pilot. The current set of objective tasks is delivered by an external component, the Task Distribution module. The active subjective tasks of the SA model are updated by the Intention inference module. The objective and the subjective tasks of the human operator are compared. Thus it can be determined if the operator performs the tasks which are appropriate for the current situation. With an eye-tracker it would also be possible to consider the basic information elements. These elements are then updated in the subjective model whenever the pilot gazes on the corresponding cockpit instrument.

#### IV. INTEGRATION INTO A-PIMOD ARCHITECTURE

The A-PiMod architecture consists of several new components which do not exist in present cockpits. The aim is to provide further assistance and to improve the interaction between the human pilots and the automation. The new components are Mission Level Situation Determination, Mission Level Risk Assessment, Cockpit Level Situation Determination, Task Determination at Cockpit Level, Task Distribution, Cockpit Level Risk Assessment, Human Machine Multimodal Interface (HMMI), HMMI Interaction Manager and Crew State Inference. The Crew State Inference communicates with the components as shown in Figure 4. Input data is received from the Mission Level Situation Determination, the HMMI and the Task Distribution. The output of the CSI module is aggregated by the Cockpit Level Situation Determination and then processed by the Cockpit Level Risk Assessment and the Task Distribution. The CSI also provides input for the HMMI Interaction Manager

Mission Level Situation Determination delivers context information like the progress on flight plan, the state of aircraft systems and environmental data (e.g., weather, ATC). The data of this component are treated as general observations of context in the CSI intention inference module.

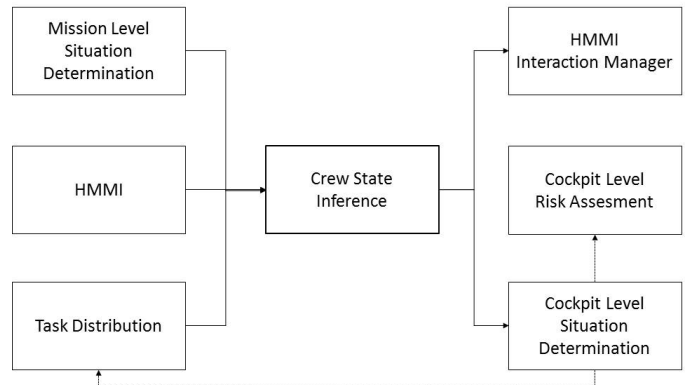

Figure 4: Crew State Inference module connections to other modules inside the A-PiMod architecture (connections between most of the other modules were intentionally left out)

The HMMI handles interactions of the human crew members with the cockpit in several modalities. The supported modalities are conventional buttons, touch, speech and gestures. Additionally, this component tracks the eye movements of the human crew members. Thus, HMMI delivers the actions and the gaze information of the pilots which are interpreted by the CSI.

The Task Distribution component receives, from the Task Determination at Cockpit Level, the tasks which are pertinent for the given situation. Every pertinent task is then assigned to at least one crew member (including automation) which is capable of performing this task. To elaborate a new task distribution the component considers the capabilities and the state of all available crew members, including human pilots and automation systems. The currently active task distribution is communicated to the CSI and consists of a set of tasks for each crew member. The tasks of a set are the so-called objective tasks of a human operator.

The Cockpit Level Situation Determination aggregates the states of all crew members. This means it monitors the state of all automation systems and receives the state of the human pilots from the CSI component. This information is then delivered to the Task Distribution component and the Cockpit Level Risk Assessment component.

Cockpit Level Risk Assessment evaluates the risk for task distributions. Here, the state of the human crew members and the state of the automation system is taken into account. Only if the risk for a task distribution is below a certain threshold this task distribution can be activated. If there are more than one possible task distribution available usually the one with the lowest risk is activated.

The purpose of the HMMI Interaction Manager is to modify the salience and the modality of the HMMI output to the human crew members. This means, e.g., if a human crew member is not aware of some information, the Interaction Manager can make the information on the display more salient. If the human crew member currently has a high visual workload, the Interaction Manager could also switch the output modality of the information to speech.

## V. CONCLUSION

In this paper, we presented the concept of the A-PiMod pilot model, which uses a mixed modelling approach (cognitive and probabilistic) to infer intentions, situation awareness, and workload of a pilot crew. The pilot model is embedded into the A-PiMod architecture and relies on the data generated by other modules. A first prototype of the pilot model has been integrated and the communication with other modules has been tested within a simulator setting at the German Aerospace Center. The next steps will be to improve the concept and the implementation, in order to be ready for a first validation of the promised functions.

## ACKNOWLEDGMENT

The A-PiMod project is funded by the European Commission Seventh Framework Programme (FP7/2007-2013) under contract number: 605141 Project A-PiMod.

## REFERENCES

- [1] R. Amalberti, "Automation in aviation: A human factors perspective," in *Handbook of aviation human factors*. Lawrence Erlbaum Associates Mahwah, NJ, 1999, pp. 173–192.
- [2] R. Parasuraman and V. Riley, "Humans and automation: Use, misuse, disuse, abuse," in *Human Factors: The Journal of the Human Factors and Ergonomics Society*, vol. 39, no. 2. SAGE Publications, 1997, pp. 230–253.
- [3] R. Parasuraman and C. Wickens, "Humans: Still vital after all these years of automation," in *Human Factors and Ergonomics Society*, vol. 50, no. 3. Sage Publications, 2008, pp. 511–520.
- [4] L. Bainbridge, "Ironies of automation," in *Automatica*, vol. 19, no. 6. Elsevier, 1983, pp. 775–779.
- [5] H. Sogame and P. Ladkin, "Aircraft accident investigation report 96-5. Japan: Ministry of transport," 1996. [Online]. Available: <http://sunnyday.mit.edu/accidents/nag-1.html> [retrieved: 1,2015]
- [6] "Applying pilot models for safer aircraft." [Online]. Available: <http://www.apimod.eu> [retrieved: 2,2015]
- [7] A. Mavor et al., *Modeling human and organizational behavior: Application to military simulations*. National Academies Press, 1998.
- [8] K. Leiden et al., "A review of human performance models for the prediction of human error," in *Ann Arbor*, vol. 1001, 2001, p. 48105.
- [9] J. Rasmussen, "Skills, rules, and knowledge; signals, signs, and symbols, and other distinctions in human performance models," in *Systems, Man and Cybernetics, IEEE Transactions on*, vol. 12, no. 3. IEEE, 1983, pp. 257–266.
- [10] F. Frische, J.-P. Osterloh, and A. Lüdtkke, "Modelling and validating pilots visual attention allocation during the interaction with an advanced flight management system," in *Human Modelling in Assisted Transportation*. Springer, 2011, pp. 165–172.
- [11] F. E. Ritter et al., "Techniques for modeling human performance in synthetic environments: A supplementary review," DTIC Document, Tech. Rep., 2003.
- [12] A. Newell, *Unified theories of cognition*. Harvard University Press, 1994.
- [13] J. R. Anderson and C. Lebiere, *The atomic components of thought*. Psychology Press, 1998.
- [14] J. R. Anderson, *How can the human mind occur in the physical universe?* Oxford University Press, 2007.
- [15] A. Newell and H. A. Simon, *GPS, a program that simulates human thought*. Defense Technical Information Center, 1961.
- [16] J. F. Lehman, J. E. Laird, and P. S. Rosenbloom, "A gentle introduction to Soar, an architecture for human cognition," in *Invitation to cognitive science*, vol. 4. MIT Press, 1996, pp. 212–249.
- [17] K. M. Corker and B. R. Smith, "An architecture and model for cognitive engineering simulation analysis: Application to advanced aviation automation," in *Proceedings of the AIAA Computing in Aerospace 9 Conference*, 1993, pp. 1079–1088.
- [18] B. F. Gore, "Workload as a Performance Shaping Factor for Human Performance Models," in *Behavioral Representation in Modeling and Simulation (BRIMS)*, 2011, p. 276.
- [19] J. R. Anderson, *Rules of the mind*. Psychology Press, 2014.
- [20] A. Newell, P. S. Rosenbloom, and J. E. Laird, "Symbolic architectures for cognition," DTIC Document, Tech. Rep., 1989.
- [21] J. R. Anderson et al., "An integrated theory of the mind," in *Psychological review*, vol. 111, no. 4. American Psychological Association, 2004, p. 1036.
- [22] R. E. Wray and R. M. Jones, "Considering Soar as an agent architecture," in *Cognition and multi-agent interaction: From cognitive modeling to social simulation*, vol. 33, 2006, pp. 53–78.
- [23] K. M. Corker, "Cognitive models and control: Human and system dynamics in advanced airspace operations," in *Cognitive engineering in the aviation domain*, vol. 31. Lawrence Erlbaum Associates, 2000, pp. 13–42.
- [24] M. A. Freed, "Simulating human performance in complex, dynamic environments," Ph.D. dissertation, Northwestern University, 1998.
- [25] W. Zachary, T. Santarelli, J. Ryder, and J. Stokes, "Developing a multi-tasking cognitive agent using the COGNET/iGEN integrative architecture," DTIC Document, Tech. Rep., 2000.
- [26] A. Lüdtkke, L. Weber, J.-P. Osterloh, and B. Wortelen, "Modeling Pilot and Driver Behavior for Human Error Simulation," in *Digital Human Modeling*, ser. Lecture Notes in Computer Science, V. Duffy, Ed., vol. 5620. Springer, 2009, pp. 403–412. [Online]. Available: [http://dx.doi.org/10.1007/978-3-642-02809-0\\_43](http://dx.doi.org/10.1007/978-3-642-02809-0_43) [retrieved: 1,2015]
- [27] C. Wickens et al., "Modeling and evaluating pilot performance in nextgen: Review of and recommendations regarding pilot modeling efforts, architectures, and validation studies," NASA Ames Research Center, Moffett Field, CA, Tech. Rep. NASA/TM-2013-216504, 2013.
- [28] A. Lüdtkke and J.-P. Osterloh, "Simulating perceptive processes of pilots to support system design," in *Human-Computer Interaction–INTERACT 2009*. Springer, 2009, pp. 471–484.
- [29] B. Wortelen, A. Lüdtkke, and M. Baumann, "Integrated simulation of attention distribution and driving behavior," in *Proceedings of the 22nd Annual Conference on Behavior Representation in Modeling & Simulation*, W. G. Kennedy, R. S. Amant, and D. Reitter, Eds. Ottawa, Canada: BRIMS Society, 2013, pp. 69–76.
- [30] A. Lüdtkke, J.-P. Osterloh, T. Mioch, F. Rister, and R. Loojze, "Cognitive modelling of pilot errors and error recovery in flight management tasks," in *Human Error, Safety and Systems Development*. Springer, 2010, pp. 54–67.
- [31] M. Hayashi, "Hidden Markov Models for analysis of pilot instrument scanning and attention switching," Ph.D. dissertation, Massachusetts Institute of Technology, 2004.
- [32] D. Donath, "Verhaltensanalyse der Beanspruchung des Operateurs in der Multi-UAV-Führung," Dissertation, Universität der Bundeswehr München, 2012.
- [33] C. Moebus and M. Eilers, "Prototyping Smart Assistance with Bayesian Autonomous Driver Models," in *Handbook of Research on Ambient Intelligence and Smart Environments: Trends and Perspectives*, N.-Y. Chong and F. Mastrogiovanni, Eds. IGI Global, May 2011, pp. 460–512. [Online]. Available: <http://www.igi-global.com/chapter/prototyping-smart-assistance-bayesian-autonomous/54671> [retrieved: 1,2015]
- [34] G. Agamennoni, J. I. Nieto, and E. M. Nebot, "A bayesian approach for driving behavior inference," in *2011 IEEE Intelligent Vehicles Symposium (IV)*, no. Iv. Ieee, 2011, pp. 595–600.
- [35] M.-I. Toma and D. Datcu, "Determining car driver interaction intent through analysis of behavior patterns," in *Technological Innovation for Value Creation*. Springer, 2012, pp. 113–120.
- [36] E. Horvitz, J. Breese, D. Heckerman, D. Hovel, and K. Rommelse, "The Lumiere project: Bayesian user modeling for inferring the goals and needs of software users," in *Proceedings of the Fourteenth conference on Uncertainty in artificial intelligence*. Morgan Kaufmann Publishers Inc., 1998, pp. 256–265. [Online]. Available: <http://dl.acm.org/citation.cfm?id=2074124> [retrieved: 1,2015]
- [37] M. Strohal and R. Onken, "Intent and error recognition as part of a knowledge-based cockpit assistant," in *Proc. SPIE*, vol. 3390, 1998,

- pp. 287–299. [Online]. Available: <http://dx.doi.org/10.1117/12.304818> [retrieved: 1,2015]
- [38] C. W. Pleydell-Pearce, B. Dickson, and S. Whitecross, “Cognition monitor: a system for real time pilot state assessment,” in *Contemporary Ergonomics*. Taylor & Francis Group, 2000, pp. 65 – 69. [Online]. Available: [http://research-information.bristol.ac.uk/en/publications/cognition-monitor-a-system-for-real-time-pilot-state-assessment\(fbd8abacd-d97e-4963-b042-c8a5e4a5f5dd\).html](http://research-information.bristol.ac.uk/en/publications/cognition-monitor-a-system-for-real-time-pilot-state-assessment(fbd8abacd-d97e-4963-b042-c8a5e4a5f5dd).html) [retrieved: 1,2015]
- [39] K. S. Moore, “Comparison of Eye Movement Data to Direct Measures of Situation Awareness for Development of a Novel Measurement Technique in Dynamic, Uncontrolled Test Environments,” Ph.D. dissertation, Clemson University, 2009.
- [40] M. Diez et al., “Tracking pilot interactions with flight management systems through eye movements,” in *Proceedings of the 11th International Symposium on Aviation Psychology*, 2001, pp. 1–6.
- [41] D. Donath and A. Schulte, “Behavior Model Based Recognition of Critical Pilot Workload as Trigger for Cognitive Operator Assistance,” in *Engineering Psychology and Cognitive Ergonomics*. Springer, 2009, pp. 518–528.
- [42] T. C. Hankins and G. F. Wilson, “A comparison of heart rate, eye activity, EEG and subjective measures of pilot mental workload during flight,” in *Aviation, Space, and Environmental Medicine*, vol. 69, no. 4, 1998, pp. 360–367.
- [43] P. R. Cohen and H. J. Levesque, “Intention is choice with commitment,” in *Artificial Intelligence*, vol. 42, no. 2-3, Mar. 1990, pp. 213–261. [Online]. Available: <http://linkinghub.elsevier.com/retrieve/pii/0004370290900555> [retrieved: 1,2015]
- [44] C. D. Wickens, “Processing Resources in Attention,” in *Varieties of attention*. Academic Press, 1984, pp. 63–102.