

Reception for Layered STBC Architecture in WLAN Scenario

Piotr Remlein

Chair of Wireless Communications
Poznan University of Technology
Poznan, Poland
e-mail: remlein@et.put.poznan.pl

Hubert Felcyn

Chair of Wireless Communications
Poznan University of Technology
Poznan, Poland
e-mail: hubert.felcyn@gmail.com

Abstract—In this paper, reception for multi-stream Orthogonal Frequency Division Multiplexing (OFDM) transmission is analyzed. The system architecture employs Linear Dispersion Space-Time Block Codes (LD-STBC). In the transmitter, a part of spatial streams is Space Time Block Coded (STBC). The LD-STBC-VBLAST OFDM receiver is described and analyzed. The quality of reception for Wireless-LAN (WLAN) transmission with channel type E is investigated using a computer simulation. We present the simulation results for two models of OFDM receivers. Performance of VBLAST and LD-STBC-VBLAST receivers has been compared. The Bit Error Rate (BER) and Packet Error Rate (PER) have been determined for different numbers of spatial streams in use. The results illustrate that the LD-STBC-VBLAST OFDM receiver improves the transmission quality in WLAN scenario.

Keywords—multi-antenna transmission; receiver; space time block coding; wireless networks.

I. INTRODUCTION

In recent years, WLANs have gained on popularity. This is due to the fact that thanks to the advanced technologies they already offer high quality (with low error rate) and high speed transmissions. Simultaneously, constant grow of demand in even higher network throughput and quality transmission are observed. Therefore, insightful research on WLANs is necessary to change the existing standards [1]. As theoretical and practical research carried out lately [2-4] has shown, transmission through multi-path wireless channels may improve the system's capacity if used adequately. According to B  olskei and Paulraj [3] a Multiple Input Multiple Output (MIMO) system enables increasing of a wireless channel's capacity proportionally to the growing number of transmit and receive antennae. A practical implementation of a MIMO system is shown by Wolniansky et al. [5]. It is the so-called Vertical Bell Laboratories Layered Space Time (VBLAST) system, which has a simple structure, yet it offers high spectral efficiency. In VBLAST, a single data stream is divided into several sub-streams transmitted simultaneously by several antennae as a result of which transmission speed may be improved.

Literature suggests many options to form receivers that would receive signals transmitted in MIMO system [2-5]. One of the methods is Maximum Likelihood (ML). This detection method offers the lowest error rate but is rather

difficult to implement. Wolniansky et al. [5] propose MIMO signal detection based on the Zero-Forcing (ZF) criterion. The ZF method is characterized by relatively low computational requirements. However, its weakness is certainly the so-called noise enhancement occurring in the case of minor SNR values. Considerably effective detection algorithms that use the so-called QR decomposition of channel matrix have been proposed in [6] [7]. Another advantage of MIMO transmission is quality improvement with reference to drop in error rate. This is obtained by using Space Time Block Codes (STBC) [8].

The superior purpose of spatial multiplexing is to maximize data transmission speed while the essence of space-time coding is to ensure high quality resulting from maximizing the diversification. These two advantages offered by MIMOs exclude each other. The so-called Linear Dispersion (LD) method was proposed by Hassibi and Hochwald [9]. The method attempts to use both the aforesaid advantages of MIMO transmission: spatial multiplexing and diversification gain. As test results show [9-11], owing to the method high transmission speed may be obtained with any configuration of antenna systems on both sides of the radio connection with simultaneous code gain. Solutions known for the MIMO transmission, such as the VBLAST [5] algorithm or ZF, may be applied for receiving [4-7].

The LD-STBC-VBLAST method was used by the authors for OFDM transmission in a WLAN system. Simulation results for selected receive algorithms that may be used for WLAN 802.11n MIMO/OFDM system are presented. Performance, in the terms of BER, LD-STBC-VBLAST and VBLAST receivers has been compared. The analyzed system uses a multi-stream transmission in which a part of spatial streams is STBC-coded and a part is transmitted without coding. It was assumed that individual subcarriers are modulated with 2-PSK, 4-PSK or 16-QAM signal. The purpose hereof is to compare the operation of the aforesaid system for two different receivers: LD-STBC-VBLAST, using the LD (Linear Dispersion) algorithm [9] and VBLAST [5] and to check the suitability of the abovementioned receivers for the improvement of data transmission quality in WLAN 802.11n.

The BER and PER were determined for the E type transmission channel model [12]. The simulation referred to transmission through E type WLAN channel because, as test

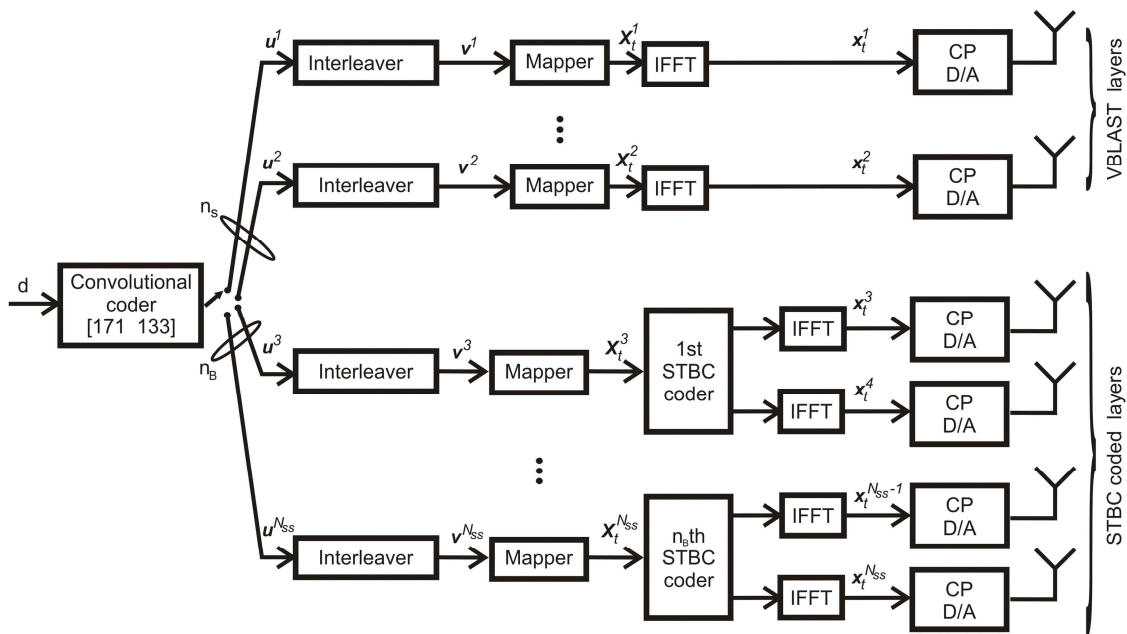

Figure 1. Scheme of the transmit part of analyzed system.

results shown by Kotrys et al. in e.g. [4], the lowest error rate has been obtained in a MIMO transmission using the channel. It was also assumed that the Channel State Information (CSI) is known in the receiver.

This paper is organized as follows: Section 2 describes the simulation model. Section 3 presents the reception algorithms used in researches. Section 4 contains simulation results that have been carried out, and, finally, Section 5 includes a summary and conclusions.

II. SYSTEM MODEL

In order to assess the quality of operation of the LD-STBC-VBLAST receiver in WLAN, many simulation experiments have been made. We used to the simulation the MATLAB environment. The model of the simulated system enables BER and PER determination. A block diagram of the transmitting part of the simulated system is presented in Fig. 1.

In the transmitter, the information sequence d is coded by a convolutional encoder [171 133] with rate $R=1/2$, used in the 802.11n standard [1]. The coded u sequence generated by the encoder is divided into N_{ss} spatial streams $u^1, \dots, u^{N_{ss}}$. Three different variants of MIMO transmissions are possible: a non-coded multistream transmission, an STBC-coded stream transmission, a transmission where a part of streams is non-coded and a part is STBC-coded.

Each of the spatial streams is subject to interleaving in blocks reflecting the successively assigned OFDM symbols as per the 802.11n recommendation [1]. Depending on the valence of the applied modulation, the bits of the interleaved sequence v are adequately grouped and mapped into the elements of 2-PSK, 4-PSK or 16-QAM constellations. Signals $X_i(k)$ represent the signals transmitted on the k -subcarrier of the OFDM symbol. Signals that modulate subcarriers within the t -symbol OFDM form a vector of X_t signals. Samples of the OFDM symbol in time domain are formed using the Inverse Fast Fourier Transform (IFFT)

algorithm. They make up the x_t vector. Then, samples of the OFDM symbol are supplemented with a Cyclic Prefix (CP) and transformed from Digital to Analogue (D/A).

To adhere to the 802.11n standard [1], in the tested system, each OFDM symbol uses the 52 sub-carriers to transmit data, 4 subcarriers are used to transmit the so-called pilot signals. OFDM is performed with the use of the 64-point Fourier transform. The duration time of a single OFDM symbol is $4\mu s$ with the sampling frequency of 20MHz. To avoid the intersymbol interference, the $0.8\mu s$ cyclic prefix is added. The transmission throughput of the analyzed system depends on the number of spatial streams that were used and valence of modulation applied to each subcarrier of the OFDM signal. A specification of the analyzed system variants is shown in Table I.

TABLE I. ANALYZED SYSTEM VARIANTS

Modulation	Number of spatial streams	Throughput [Mb/s]
2-PSK	2	13
2-PSK	3	19,5
4-PSK	2	26
4-PSK	3	39
16-QAM	2	52
16-QAM	3	78

III. RECEPTION ALGORITHMS

In the analyzed system, data transmission is performed using two, three or four spatial streams. Correct synchronization and estimation of the channel state in the receiver was assumed. A total of signals transmitted by all transmit antennae (modified as a result of channel passing) reaches each receive antenna. The signal from receive antenna after sampling is transformed, with the Fast Fourier

Transform (FFT), from time domain to frequency domain and subsequently demodulated. Two receiving methods have been analyzed in the paper, VBLAST and LD-STBC-VBLAST receivers.

The VBLAST receive algorithm consists in iterative reduction of the intersymbol interference between signals transmitted by different transmit antennas and may be illustrated as follows [5]:

Initialization:

$$\mathbf{W}_1 = \mathbf{H}^+ \quad (1)$$

$$i = 1 \quad (2)$$

Successive iterations:

$$k_i = \arg \min_{j \in \{k_1, \dots, k_{t-1}\}} \|(\mathbf{W}_i)_j\| \quad (3)$$

$$y_{k_i} = (\mathbf{W}_i)_{k_i} \mathbf{r}_i \quad (4)$$

$$\hat{a}_{k_i} = Q(y_{k_i}) \quad (5)$$

$$r_{i+1} = r_i - \hat{a}_{k_i} (\mathbf{H})_{k_i} \quad (6)$$

$$\mathbf{W}_{i+1} = \mathbf{H}_{k_i}^+ \quad (7)$$

$$i = i + 1, \quad (8)$$

where: \mathbf{r} is received signal vector, \mathbf{H}^+ is matrix of Moore-Penrose pseudo-inversion of the channel matrix \mathbf{H} [1], $(\mathbf{W}_i)_j$ is its j -row of matrix \mathbf{W}_i , $Q(\cdot)$ is the function of decision that selects the closest, in terms of Euclid's distance, point from the constellation of signals modulating individual subcarriers, $(\mathbf{H})_{k_i}$ is the k_i -column of matrix \mathbf{H} , \mathbf{H}_{k_i} is the matrix obtained through clearing columns k_1, \dots, k_i of matrix \mathbf{H} [4][5].

The receive method based on the LD-STBC-VBLAST algorithm has been adopted by Longoria-Gandara et al. [10] to OFDM WLAN transmission. The method is applied in the case where in the MIMO system non-coded streams are transmitted by selected antennae and simultaneously STBC coded streams are transmitted by other antennae.

The transmit part of the LD-STBC-VBLAST system is presented in Fig. 1. The basic idea of the systems is concurrent transmission of spatial streams both non-coded and space-time block coded. Then, it was assumed to denote the system having n_S of non-coded spatial streams and n_B of STBC coded spatial streams as (n_S, n_B) -LD-STBC-VBLAST, for example the description (0,2) denotes the system which use two STBC encoded streams.

In the LD-STBC-VBLAST receiver, the theory of linear dispersion described by Hassibi and Hochwald [9] was used

to demodulate. Therefore, during modulation signals received from both non-coded and STBC coded streams may be treated the same.

Further on, the following designations have been assumed:

n_A – number of antennae in a single STBC stream;

N_T – number of transmit antennae;

N_R – number of receive antennae;

n_B – number of STBC coded streams;

n_S – number of streams not coded with STBC

Table II below shows which signals are transmitted by two individual antennae in subsequent time intervals [11]. This constitutes a description of the time and space coding performed for a given antenna configuration [9].

TABLE II. TRANSMITTED SIGNALS

Non-coded streams		STBC coded streams STBC block: $\mathbf{B}=\mathbf{I}, \dots, \mathbf{B}_B$	
Time	Antenna $i=1, \dots, n_S$	Antenna 1	Antenna 2
T	$S_{i,j}$	$S_{n_A,1}$	$S_{n_A,2}$
t+T	$S_{i,2}$	$-S_{n_A,2}^*$	$S_{n_A,1}^*$

The signal reaching the receiver is presented as follows [10]:

$$\begin{bmatrix} y_1^{(1)} & y_1^{(2)} \\ y_2^{(1)} & y_2^{(2)} \\ \vdots & \vdots \\ y_{N_R}^{(1)} & y_{N_R}^{(2)} \end{bmatrix} = \begin{bmatrix} h_{11} & h_{12} & \dots & h_{1N_T} \\ h_{21} & h_{22} & \dots & h_{2N_T} \\ \vdots & \vdots & \ddots & \vdots \\ h_{N_R1} & h_{N_R2} & \dots & h_{N_R N_T} \end{bmatrix} \begin{bmatrix} \mathbf{S}_{n_C} \\ \mathbf{S}_C \end{bmatrix} + \begin{bmatrix} n_1^{(1)} & n_1^{(2)} \\ n_2^{(1)} & n_2^{(2)} \\ \vdots & \vdots \\ n_{N_R}^{(1)} & n_{N_R}^{(2)} \end{bmatrix} \quad (9)$$

In the above, as well as in the formulas that follow, the below notation has been applied:

- the subscripts signify numbers of relevant antennae;
- the superscripts signify the number of modulation interspace in a given time interval

The transmitted signal is specified as $\begin{bmatrix} \mathbf{S}_{n_C} \\ \mathbf{S}_C \end{bmatrix}$. It is composed of two separate matrixes of which each describes symbols transmitted in relevant streams: nC – non-coded and C – STBC-coded.

$$\mathbf{S}_{n_C} = \begin{bmatrix} S_1^{(1)} & S_1^{(2)} \\ S_2^{(1)} & S_2^{(2)} \\ \vdots & \vdots \\ S_{n_S}^{(1)} & S_{n_S}^{(2)} \end{bmatrix} \quad (10)$$

$$\mathbf{S}_C = \begin{bmatrix} \mathbf{S}_1^C \\ \vdots \\ \mathbf{S}_{n_B}^C \end{bmatrix} = \begin{bmatrix} \mathbf{S}_1^{(1)C} & \mathbf{S}_1^{(2)C} \\ \vdots & \vdots \\ \mathbf{S}_{n_B}^{(1)C} & \mathbf{S}_{n_B}^{(2)C} \end{bmatrix} \quad (11)$$

And where each matrix element (13) is given as [10]:

$$[\mathbf{S}_B^{(1)C} \quad \mathbf{S}_B^{(2)C}] = \begin{bmatrix} s_{n_A,1} & -s_{n_A,2}^* \\ s_{n_A,2} & s_{n_A,1}^* \end{bmatrix}, \quad (12)$$

where $B=1, \dots, n_B$.

By applying the LD theory [9] equation (11) may be noted as follows [10]:

$$\begin{bmatrix} y_1^{(1)} \\ y_1^{(2)*} \\ \vdots \\ y_{N_R}^{(1)} \\ y_{N_R}^{(2)*} \end{bmatrix} = [\mathbf{H}_{nc} \quad \mathbf{H}_c] \mathbf{S}_{LD} + \begin{bmatrix} n_1^{(1)} \\ n_1^{(2)*} \\ \vdots \\ n_{N_R}^{(1)} \\ n_{N_R}^{(2)*} \end{bmatrix} \quad (13)$$

In the matrix notation, equation (15) may be noted like this:

$$\mathbf{Y}_{LD} = \mathbf{H}_{LD} \mathbf{S}_{LD} + \mathbf{N}_{LD}, \quad (14)$$

where all matrixes are called LD matrixes.

The matrix of the transmitted signal may also have the form of the LD matrix:

$$\mathbf{S}_{LD} = \begin{bmatrix} \mathbf{S}_{LD}^{nC} \\ \mathbf{S}_{LD}^C \end{bmatrix}, \quad (15)$$

In the receiver, similarly to [10], the so-called QR decomposition of the channel matrix \mathbf{H} is used.

This decomposition consists in splitting the channel matrix into two matrixes whose product equals the channel matrix:

$$\mathbf{H}_{LD} = \mathbf{Q}_{LD} \mathbf{R}_{LD} \quad (16)$$

Matrix \mathbf{Q} is a rectangular matrix $2N_R \times n_{SYM}$. Whereas matrix \mathbf{R} is a square, upper triangular matrix $n_{SYM} \times n_{SYM}$, where $n_{SYM}=2(n_S+n_B)$. A detailed description of the QR decomposition algorithm may be found in [6].

After determining the \mathbf{Q} and \mathbf{R} matrix for the \mathbf{H} channel matrix, linear detection of the received signal takes place in the receiver. The detection algorithm [7] is as follows:

Initialization:

$$k = N_T \quad (17)$$

$$\mathbf{w} = \mathbf{Q}^H \mathbf{n} \quad (18)$$

$$\tilde{\mathbf{s}} = \mathbf{Q}^H \mathbf{y} = \mathbf{R} \mathbf{s} + \mathbf{w} \quad (19)$$

Successive iterations (1):

$$\hat{s}(k) = Q \left[\tilde{s}(k, k) / R(k, k) \right] \quad (20)$$

$$k = k - 1 \quad (21)$$

If k equals 0 – end of algorithm operation

$$i = k + 1 \quad (22)$$

$$interf(k) = 0 \quad (23)$$

Successive iterations (2):

$$interf(k) = interf(k) + R(k, i) \cdot \hat{s}(i) \quad (24)$$

$$i = i + 1 \quad (25)$$

End of loop (2)

$$\tilde{\mathbf{s}} = \mathbf{R} \mathbf{s} + \mathbf{w} - \mathbf{interf} \quad (26)$$

or

$$\tilde{\mathbf{s}} = \mathbf{Q}^H \mathbf{y} - \mathbf{interf} \quad (27)$$

End of loop (1).

where, \mathbf{y} is received signal vector, \mathbf{s} is transmit signal vector, $\tilde{\mathbf{s}}$ decision statistic for transmit signal, $\hat{\mathbf{s}}$ estimate for transmit signal, \mathbf{Q}^H the hermitian transpose of \mathbf{Q} , \mathbf{n} represents the white gaussian noise of variance σ_n^2 observed at the N_R receive antennae while the average transmit power of each antenna is normalized to one.

The presented detection algorithm is based on successive interference reduction. The decisions on transmitted signals $\tilde{\mathbf{s}}$ are determined allowing for the calculated information on interfering signals (*interf*) coming from other transmit antennae.

IV. SIMULATION RESULTS

By means of the computer simulation, we have determined the BER and PER depending on the SNR value. An assumption has been made that transmission takes place in E type WLAN channel [12]. A comparison of the quality of MIMO systems operation using the following two types of receivers has been presented: LD-STBC-VBLAST and VBLAST depending on the number of spatial streams and selected modulations: 2-PSK, 4-PSK, 16-QAM. In the simulations, ideal synchronization has been assumed as well

as that the receiver knows the CSI. The transmitted packets were 1000-byte long. OFDM technique has been applied. The 64-point IFFT/FFT has been implemented, where data is transmitted on 52 subcarriers. Additionally, four subcarriers have been used to transmit pilot signals and 8 subcarriers constituted a protection interval. To assess correctness of operation of the proposed simulation model, a series of tests confirming the results taken from literature [4][5][7] have been performed. Different combinations of parameter setups for the investigated MIMO systems have been simulated. The most representative results have been selected for the presentation.

In Figures 2 and 3, PER and BER curves are illustrated for the VBLAST and LD-STBC-VBLAST receive systems including two and three spatial streams for different number of transmit N_t and receive N_r antennae. Transmission in these systems takes place at the speed of 52 and 78Mb/s respectively with the WLAN channel type E [12].

Considering the transmission with two spatial streams (Fig. 2), with PER at 10^{-3} , (0,2) LD-STBC-VBLAST system proved the best properties. Here, transmission takes place using four transmit and receive antennae. The (0,2) LD-STBC-VBLAST system offers 1% PER with about 17 dB. The (1,1) LD-STBC-VBLAST system including three transmit and receive antennae is by approximately 6 dB inferior. The system employing VBLAST receiver, where the number of antennae equals the number of spatial streams for the same level of PER (at 10^{-3}), is inferior to (1,1) LD-STBC-VBLAST system by 0.2 dB. The (0,2) LD-STBC-VBLAST system offers approximately 7 dB gain comparing to the (1,1) LD-STBC-VBLAST and VBLAST systems with the BER of about 10^{-4} , respectively. The throughput for these systems is equal 52Mb/s.

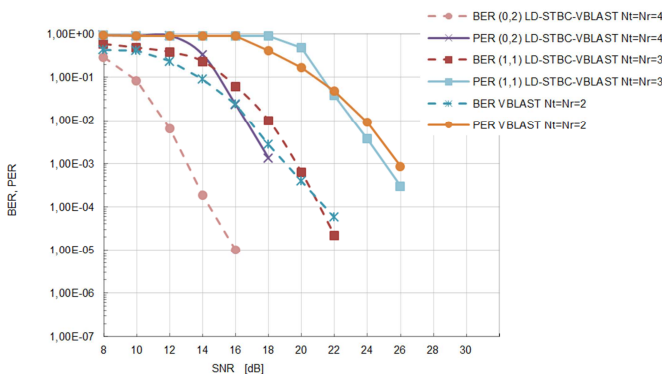

Figure 2. PER and BER for two-spatial-stream-systems, modulation 16QAM, 52Mb/s.

Fig. 3 represents the simulation results for systems with three spatial streams and obtained throughput 78Mb/s. For 1% PER the best results have been noted in the case of (1,2) LD-STBC-VBLAST system including five transmit and receive antennae. This level is obtained when SNR equals 19 dB. The (2,1) LD-STBC-VBLAST systems is inferior by

3.5 dB. It has four transmit and receive antennae. The number of antennae in the system employing VBLAST receiver equals the number of spatial streams and is equal 3. This has proven to perform (PER at 10^{-4}) poorer than the best presented (1,2) LD-STBC-VBLAST system by 6 dB. The (1,2) LD-STBC-VBLAST system offers approximately 3 dB gain comparing to the (2,1) LD-STBC-VBLAST and BLAST systems with the BER of about 10^{-4} , respectively.

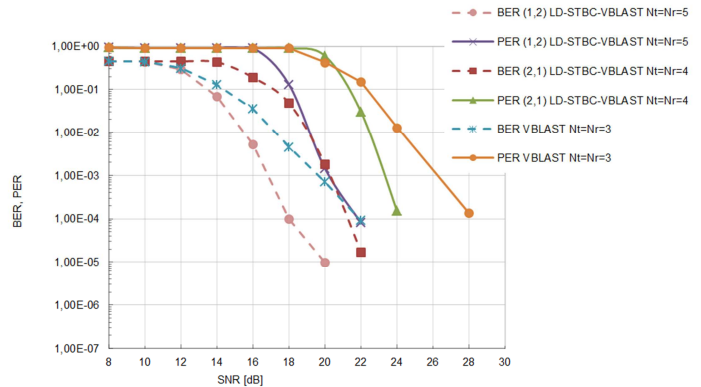

Figure 3. PER and BER for three-spatial-stream-systems, modulation 16QAM, 78Mb/s.

A system that uses LD-STBC-VBLAST receive enables enhancement of transmission speed with coincident quality improvement through application of an additional spatial stream. To improve quality, an STBC coding on additional spatial stream must be used. If the number of spatial streams grows from one to two, a 100% increment of speed is obtained with simultaneous minor improvement in PER for 2-PSK, 4-PSK and 16-QAM modulation. If the number of spatial streams grows from two to three, the speed increment is 50% with 1% improvement in PER by 3 dB for 2-PSK modulation and by 4 dB for modulations 4-PSK and 16-QAM.

V. CONCLUSION AND FUTURE WORK

This paper presented a proposal of use LD-STBC-VBLAST reception for WLAN systems with a hybrid transmission. A multistream transmission was suggested where a part of spatial streams was STBC coded and a part was transmitted without any codes. The impact of transmit diversification on the quality of transmission has been analyzed. Based on the simulation results it may be clearly observed that the transmit diversification offers better properties of the transmission system. The LD-STBC-VBLAST receiver proves the best results in BER and PER when compared to the system with a VBLAST receiver at the cost of increased number of antennae.

As it results from the performed tests, the method that has been applied (LD-STBC-VBLAST) allows increasing of the transmission speed with no deterioration of the error rate through suitable selection of the transmitted spatial streams.

The system with LD-STBC-VBLAST receiver allows iterative reduction of interference. Therefore, the BER and PER results are considerably better than in the case of the VBLAST receiver system. Given the presented simulation results, we can suppose that the investigated LD-STBC-VBLAST receiver could be successfully used in next wireless networks which are currently being developed.

As a future research task, another reception methods should be examined and complexity evaluation of investigated reception algorithms should be perform.

ACKNOWLEDGMENT

This work was partially supported by the Polish National Science Centre under research grant 2011/01/B/ST7/06578.

REFERENCES

- [1] IEEE standard for information technology–telecommunications and information exchange between systems–local and metropolitan area networks–specific requirements part 11: Wireless LAN medium access control (MAC) and physical layer (PHY) specifications amendment 5: Enhancements for higher throughput, IEEE Std 802.11n-2009 (Amendment to IEEE Std 802.11-2007 as amended by IEEE Std 802.11k-2008, IEEE Std 802.11r-2008, IEEE Std 802.11y-2008, and IEEE Std 802.11w-2009), pp. c1 –502, 29 2009.
- [2] G. J. Foschini and M. J. Gam, “Layered space-time architecture for wireless communication in a fading environment when using multiple antennae,” *Bell Labs. Syst. Tech. Journal*, vol. 1, 1996, pp. 41-59.
- [3] H. Bölcskei and A. J. Paulraj, “Multiple-input multiple-output (MIMO) wireless systems,” *The Communications Handbook*, CRC Press, 2nd ed., 2002, pp. 90.1-90.14.
- [4] R. Kotrys, M. Krasicki, P. Remlein, and P. Szulakiewicz, “Receiver Algorithms for Multi-stream Data Transmission in WLAN 802.11n Networks,” *Wireless Personal Communications*, vol. 68, 2013, pp. 1583-1594, doi: 10.1007/s11277-012-0540-7
- [5] P.W. Wolniansky, G.J. Faschini, G.D. Golden, and R.A. Valenzuela, “V-BLAST: An architecture for realizing very high data-rates over the wireless channel,” *Proc. IEEE ISSSE-98*, Pisa, Italy, 1998, pp. 295-300.
- [6] D. Wübben, R. Böhnke, J. Rinas, V. Kühn, and K.D. Kammeyer, “Efficient algorithm for decoding layered space-time codes,” *IEE Electronic Letters*, vol. 37, 2001, pp. 1348-1350.
- [7] D. Wübben, R. Böhnke, V. Kühn, and K.D. Kammeyer, “Reduced Complexity MMSE Detection for BLAST Architectures,” *Proc. IEEE GLOBECOM Conf.*, 2003, pp. 2258-2262.
- [8] V. Tarokh, H. Jafarkhani, and A. R. Calderbank, “Space-Time Block Codes from Orthogonal Designs,” *IEEE Transactions on Information Theory*, vol. 45, no. 5, 1999, pp. 1456-1467.
- [9] B. Hassibi and B.M. Hochwald, “High rate codes that are linear in space and time,” *IEEE Transactions of Information Theory*, vol. 48, no. 7, 2002, pp. 1804-1824.
- [10] O. Longoria-Gandara, A. Sanchez-Hernandez, J. Cortez, M. Bazdresch, and R. Parra-Michel, “Linear Dispersion Codes Generation from Hybrid STBC-VBLAST Architectures,” *Proc. of 4th International Conference on Electrical and Electronics Engineering*, 2007, pp. 142-145.
- [11] M. Tianyu and M. Motani, “STBC-VBLAST for MIMO wireless communication systems,” *IEEE International Conference on Communications, ICC*, vol. 4, 2005, pp. 2266- 2270.
- [12] IEEE P802.11 Wireless LANs, TGN Channel Models, IEEE 802.11-03/940r4, May 2004.