

## Extended Mobile WiMAX Signal Transmission over RoF via Triple Symmetrical Dispersion System SMF, DCF and CFBG

Mazin Al-Noor, Jonathan Loo, Richard Comley

School of Engineering and Information Sciences,  
Middlesex University, Hendon, NW4 4BT  
LONDON, UK

M.Al-Noor@mdx.ac.uk, J.Loo@mdx.ac.uk, R.Comley@mdx.ac.uk

**Abstract**— The main impediments for long distance signal transmission in the fibre optic system, especially the radio over fibre (RoF) system, are the chromatic dispersion and signal power attenuation. Additionally, the power consumption in the laser diode and optical amplifiers affect the signal transmission costs; however, it is lower than in a wireless system. Therefore, decreasing the power consumption and chromatic dispersion and increasing the data bit rate in RoF are the demands for present and future fibre optic system technology. In order to increase the signal transmission distance and improve the frequency spectrum, we study in this paper a mobile Worldwide Interoperability for Microwave Access (WiMAX) signal transmission over RoF via a triple symmetrical dispersion system. The combination of three different fibres - single mode fibre (SMF), dispersion compensating fibre (DCF) and chirped fibre Bragg grating (CFBG) - is used to transmit a 120Mbps mobile WiMAX scalable Orthogonal Frequency Division Multiple Access (OFDMA) signal with 3.5GHz carrier frequency and 20MHz bandwidth over a RoF system. To compensate the dispersion, the SMF and DCF are employed and specifically the high reflector CFBG is applied to reduce signal power loss. In our study, the WiMAX signal is transmitted through a triple symmetrical dispersion system consisting of 2xDCF (20 km) and 2xSMF (100 km) connected to SMF (24 km) and CFBG. Simulation results clearly indicate that the limited signal transmission length and data bit rate in the RoF system, caused by fibre attenuation and chromatic dispersion, can be overcome by the combination of SMF, DCF and CFBG. The transmission distance in the fibre is extended to 792 Km, SNR and OSNR are highly satisfactory; simultaneously the power consumption is decreased.

**Keywords**- *Worldwide Interoperability for Microwave Access (WiMAX); Radio over Fibre (RoF); Dispersion Compensating Fibre (DCF); Chirped Fibre Bragg Grating (CFBG); Single Mode Fibre (SMF).*

### I. INTRODUCTION

The communication systems such as wireless broadband and mobile broadband systems offer better client service, by enhancing mobility, accessibility and simplicity of communication between people. Therefore, there has been growing interest in WiMAX systems, WiMAX IEEE 802.16 and 802.16e-2005 mobile [1]. In comparison to Universal Mobile Telecommunication System (UMTS) and Global System for Mobile communications (GSM), WiMAX offers an enlarged significant bandwidth by using the channel

bandwidth of 20 MHz and an improved modulation technique (64-QAM).

When equipments are operating with low-level modulation and high-power amplifiers, WiMAX systems are capable to serve larger geographic coverage areas, and they support the different modulation technique constellations, such as BPSK, QPSK, 16-QAM and 64-QAM[2][3]. WiMAX physical layer consist of OFDM, which offers resistance to multipath. It permits WiMAX to operate in non-line-of-sight environments (NLOS) and is highly understood for alleviating multipath for wireless broadband. WiMAX provides modulation and forward error correction (FEC) coding schemes adapting to channel conditions; it may be changed per user and per frame [2].

The electrical distribution of high-frequency microwave signals through either free space or transmission lines causes difficulties and costs. Losses increase with frequency in free space, due to absorption and reflection; and in transmission lines impedance rises with frequency, which leads to very high losses. Therefore, expensive regenerating equipment is required to distribute high-frequency radio signals electrically over long distances. The alternative would be to distribute baseband signals, radio frequency (RF) signals or signals at low intermediate frequencies (IF) from the control station (CS) to the base station (BS) and subsequently to the user. The RF or baseband signals are down-converted to the required microwave or mm-wave frequency at each BS, amplified and transmitted. Reverse, from user to the BS, the signals would be up-converted [4].

The radio in millimeter-wave (mm-wave) band is the promising media to transmit the ultra-broadband signal in the wireless telecommunication system and, since the recent ten years, has been developing to a favorite research topic. By optics method the mm-wave signal is readily generated and can be transmitted through a long fiber distance. In the RoF system, the generation of the optical mm-wave is one of the key techniques. Several techniques to generate the optical mm-wave at around 60 to 120GHz have been reported, including direct modulation of laser diode (LD), heterodyne technique with optical phase locking, electrical sub-harmonic injection and external modulation. Of all these techniques, the optical external modulation is an appropriate option to generate the optical mm-wave signal with high spectral purity [5].

RoF systems are analogue fibre optic links, which are used to transmit demodulation signal carrier of radio

frequency (RF) directly or indirectly from a CS to a BS through a remote unit antenna (RAU) or radio access antenna (RAP) to the client [6].

In order to find leading techniques for the WiMAX network deployment, RoF has been studied extensively in recent years. Many studies have been focused on the fibre [7][8][9][10], the low attenuation (0.2 dB/km), and high performance solution for high-speed fibre based on wireless access.

The utilization of millimeter-wave (MMW) frequency for high-speed wireless access, in future RoF systems, would meet the requirement of high bandwidth and overcome the spectral congestion at low frequency. Surely, the RoF system is the future network technology, which has on one hand the capacity to satisfy the demands for decreasing electromagnetic smoking, wireless traffic, power, noise, cost, and antenna size and, on the other hand, to increase frequency, bandwidth, data rate and capacity also eventually improves the spectral efficiency.

So far, the investigations have been narrowed to resolve the dispersion effect and to control the chromatic dispersion, which is explained in Section II, the signal distortion also reduce the power and increase the transmission distance [11]. In our study, the compensators methods are used to equalize the dispersion slope in a fibre and have been demonstrated in the form of DCF and CFBG. DCF has proved to be effective to overcome chromatic dispersion in high velocity light; with a special design, consisting of a fibre and a negative dispersion slope, it compensates the positive dispersion in SMF. We also use an optical amplifier and a CFBG, due to the high insertion loss of DCF, which is discussed in Section III and IV.

CFBG is a high Bragg reflector placed in a short segment of an optical fibre, used to correct chromatic dispersion. It can be used as a wavelength-specific reflector or as an inline optical fibre. CFBGs are extensively employed for functions such as dispersion compensation, stabilizing laser diodes, and add/drop multiplexing in optical fibre systems. The CFBGs comply with environmental requirements by increased stability and durability (free from rust), they can be highly multiplexed (many sensing points in a single fibre cable), and have the advantage of low power attenuation through transmission over several kilometers [12].

This paper studies methods to increase the WiMAX signal transmission distance through utilizing a RoF system with the aim to reduce power consumption and to obtain satisfactory OSNR, SNR and high quality signal transmission spectrums. The work focuses on WiMAX signals transmitted over RoF by applying SMF, DCF and CFBG. The paper is organized as follows. In Section II, we focus on related work; in Section III, we describe the theory of light dispersion in the fibre optic cable for SMF, DCF and for CFBG. In Section IV, we introduce the system description of WiMAX and RoF system and describe the design of the complete system. We discuss the simulation results in Section V and finally, conclusions are drawn in Section VI.

## II. RELATED WORK

As mentioned in Section I, RoF technology as a means to deliver WIMAX signals has been studied by a number of researchers. Based on the IEEE 802.16d-2004 specification in the 3.5 GHz band, [13] reported about measured spectra and Error Vector Magnitude (EVM) for different single mode fiber spans up to 5 km.

Also, [14] investigated EVM for RoF WiMAX signal transmission. In this approach, fiber lengths between 0km and 5km for both uplink and downlink instances were investigated. The results show, on the downlink, the EVM measured was better than 3.1% between -3dBm and 10dBm. Lowest EVM was measured at 3dBm.

A hybrid radio on dense-wavelength-division-multiplexing (DWDM) transport system for WiMAX applications is proposed in [15]. The researchers were able to improve the bit error rate (BER) over a large, effective area fiber (LEAF) of 100km.

In [16], a WiMAX-RoF transport system is proposed and achieved satisfactory BER performance over a 120 km SMF length for both, down and up links.

Osadchiy et al [17] proposed a bi-directional WiMAX-over-fiber signal transmission system. The scheme supports signal transmission on a 2.4 GHz carrier at a bit rate of 100 Mb/s downlink and 64 Mb/s uplink for an 80km access fiber link. They also demonstrated a successful transport of 100 Mb/s WiMAX-compliant signals with a 5.8 GHz RF carrier over a 78.8km deployed SMF and a 40km distribution SMF. The results show that the WiMAX signal stayed within 5% RMS EVM after 118.8-km fiber link transmission and air transmission.

## III. THEORY AND ANALYSES

Dispersion is a highly important factor due to the effect on the bit rate. There are three types of dispersions: material dispersion, also known as chromatic dispersion, is caused by the fact that the refractive index of the fibre medium varies as a function of wavelengths, waveguide dispersion depends on geometrical characteristics like shape, design and chemical composition of the fibre core and finally, intermodal dispersion, which is related to the fact that the light is not transmitted as a single beam [18].

Accordingly, chromatic dispersion emerges because of variable frequency components and also signals at differing wavelengths move at different velocities due to the refractive index. It has the following units of measurement: ps/nm/km, where nm is the spectral width of the pulse, ps refers to the time spread of the pulse and km refers to the fibre length. The chromatic dispersion of SMF is 16 ps/nm/km at 1550 nm and 17ps/nm/km at 1552nm, and can be expressed as follows [19]:

$$D_{chr} = -\frac{1}{L} \frac{dt_g}{d\lambda} \quad (1)$$

where L is the fibre length and  $t_g$  is the time to disperse the distance. For externally modulated sources, transmission

distance limited by chromatic dispersion can also be expressed as follows [19]:

$$L < \frac{2\pi c}{16|D|\lambda^2 B^2} \quad (2)$$

where B is the bandwidth;  $\lambda$  is the wavelength and c is the light velocity. Eq. (1) and (2) show the transmission distance of the signal is limited due to the chromatic dispersion in the SMF. To abolish the limitation of signal transmission in the SMF, techniques like DCF and CFBG have been demonstrated to be useful to compensate the accumulated dispersion in the fibre. DCF has a dispersion characteristic that is contrary to that of the transmission fibre. Dispersion compensation is achieved by inserting an open loop of DCF into the transmission path. The total dispersion in the DCF open loop needs to be equal and opposite of the accumulated dispersion in the SMF. This means that, if the SMF has a low positive dispersion, the DCF will have a large negative dispersion. With this technique, the absolute dispersion per length is nonzero at all points along the fibre, whereas the total accumulated dispersion is zero after some distance. The length of the DCF should be minimized as the special fibre used has a higher attenuation than the transmission fibre. The attenuation is around 0.6dB/km at 1550nm compared to 0.2dB/km for SMF [20].

Because of the high power loss in DCF, the CFBG is applied to control and tune the difference in arrival times of the multiple frequency components resulting from a typical dispersion. It has been shown that strong, long, and highly reflective gratings can be used for dispersion in communication links in transmission with negligible loss aspersion, by proper design of the grating. For high-bit-rate systems, higher- order dispersion effects become important, dissipating the advantage of the grating used in transmission. The rules utilized for the design of the grating to compress pulses in a near ideal technique are a compromise between the reduction of higher-order dispersion and pulse recompression. Bandwidths are limited with this configuration by the strength of the coupling constant and length of a realizable uniform period grating.

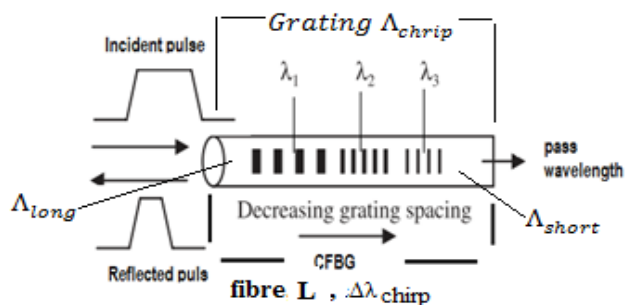

Figure 1. The wavelength reflected in CFBG by the Bragg grating referred to Bragg wave is  $\lambda_1, \lambda_2, \lambda_3$  and the unwanted wavelength passes; the spacing decreases along the fibre; accordingly, the Bragg wavelength decreases with distance along the grating length.

The reflected wavelength in CFBG amends with the grating period, because the spacing of the grating varies and is designed for a desired wavelength. The different wavelengths reflected from the grating will be subject to different delays; if the injected light wavelength differs from the grating resonant wavelength, the light is not reflected. As shown in Figure 1, the chirp in the period can be related to the chirped bandwidth  $\lambda_{chirp}$  of the fibre grating which is presented in the following equation [11]:

$$\Delta\lambda_{chirp} = 2n_{eff}(\Lambda_{long} - \Lambda_{short}) = 2n_{eff}\Delta\Lambda_{chirp} \quad (3)$$

The reflection from a chirped grating is a function of wavelength, and therefore, light entering into a positively chirped grating (increasing period from input end) suffers a delay in reflection that is approximately [11].

$$\tau(\lambda) \approx \frac{(\lambda_0 - \lambda) 2L_g}{\Delta\lambda_{chirp} v_g},$$

$$\text{for } 2n_{eff}\Lambda_{short} < \lambda < 2n_{eff}\Lambda_{long} \quad (4)$$

where  $\lambda_0$  is the Bragg wavelength at the center of the chirped bandwidth of the grating, and  $v_g$  is the average group velocity of light in the fibre. By introducing a maximum delay of  $2L_g/v_g$  between the shortest and the longest reflected wavelengths, the effect of the chirped grating is that it disperses light. This dispersion is of importance since it can be used to compensate for chromatic dispersion in optical fibre transmission systems. The figure of merit is a high-length grating with a bandwidth important feature of a dispersion-compensating device as at 1550 nm, the group delay  $\tau$  in reflection is  $\sim 10$  nsec/m. Several parameters affect the performance of the CFBGs for dispersion compensation: the insertion loss due to reflectivity  $< 100\%$ , dispersion, bandwidth, and polarization mode-dispersion, deviations from linearity of the group delay also group delay ripple. Ignoring the first and the last two parameters momentarily, we consider the performance of a chirped grating with linear delay characteristics, over a bandwidth of  $\Delta\lambda$  chirp.

The dispersion coefficient  $D_g$  [ps/nm/km] for the linear CFBG is given by the following simple expression [8]:

$$D_g = \frac{2n}{c \Delta\lambda_{chirp}} \quad (5)$$

where  $n$  is the average mode index,  $c$  is the light velocity,  $\Delta\lambda$  is the difference in the Bragg wavelengths at the two ends of the grating. Eq. (5) represents that  $D_g$  of a chirped grating is ultimately limited by the bandwidth  $\Delta\lambda$ ; the increase in the transmission distance will be possible only, if the signal bandwidth is reduced.

#### IV. SYSTEM DIScription OF WiMAX OVER RoF

An important difference between fixed and mobile WiMAX is the physical layer. Mobile WiMAX uses OFDMA as its physical layer transmission scheme instead of plain Orthogonal Frequency Division Multiplexing (OFDM). OFDMA can also be used as a multiple access mechanism when groups of data subcarriers, called sub channels, are allocated to different users. Mobile WiMAX also introduces more scalability into the actual physical layer parameters. Cyclic prefix durations and channel bandwidths in multiple OFDMAs, which have different amounts of subcarriers, are utilized to allow the wireless link design to be optimized according to the environment where the system is deployed.

Figure 2 illustrates the schematic simulation setup of WiMAX over RoF, including the dispersion model techniques SMF, DCF and CFBG. In this simulation, the BS deployed the data of mobile WiMAX IEEE 802.16e-2005 to the fibre system as a RF signal; firstly, to the RAU antenna as an electrical signal; subsequently, converted to the fibre optic signal by modulating the RF to the laser beam, which a laser diode has injected into the SMF; this modulation operation arises in the Mach Zehnder Modulator (MZM).

In future work, it would be possible to use a WiMAX Femtocell instead of a BS because it has several advantages. It can be use in microcell, pico-cell area and indoor; the

typical cell radius ranges between 50-100m[17]. The proposed scheme would not require to be changed, because, at the end of fibre, the optical signal is converted to the electrical RF signal, which would radiate via Femtocell to micro or pico-cell. The WiMAX transmission signal is centered at 3.5 GHz; comprising 128 subcarriers and 64QAM (6 bit-per-symbol) modulates each; the bandwidth is 20MHz, and the transmitted bit rate is 120Mbps. The important component in WiMAX is the scalable orthogonal frequency division multiplexing (S-OFDMA). In the basic version of OFDMA, one sub-carrier is assigned to each user. The spectrum of each user is quite narrow, which makes OFDMA more sensitive to narrowband interference. The core of an orthogonal multi-carrier transmission is the Fast Fourier transform (FFT) respectively, inverse FFT (IFFT) operation; synchronization and channel estimation process together with the channel decoding play an important role. To ensure a low cost receiver (low cost local oscillator and RF components) and to enable a high spectral efficiency, robust digital synchronization and channel estimation mechanisms are needed. The throughput of an OFDM system does not only depend on the used modulation constellation and Forward Error Correction (FEC) scheme, but also on the amount of reference and pilot symbols spent to guarantee reliable synchronization and channel estimation [23].

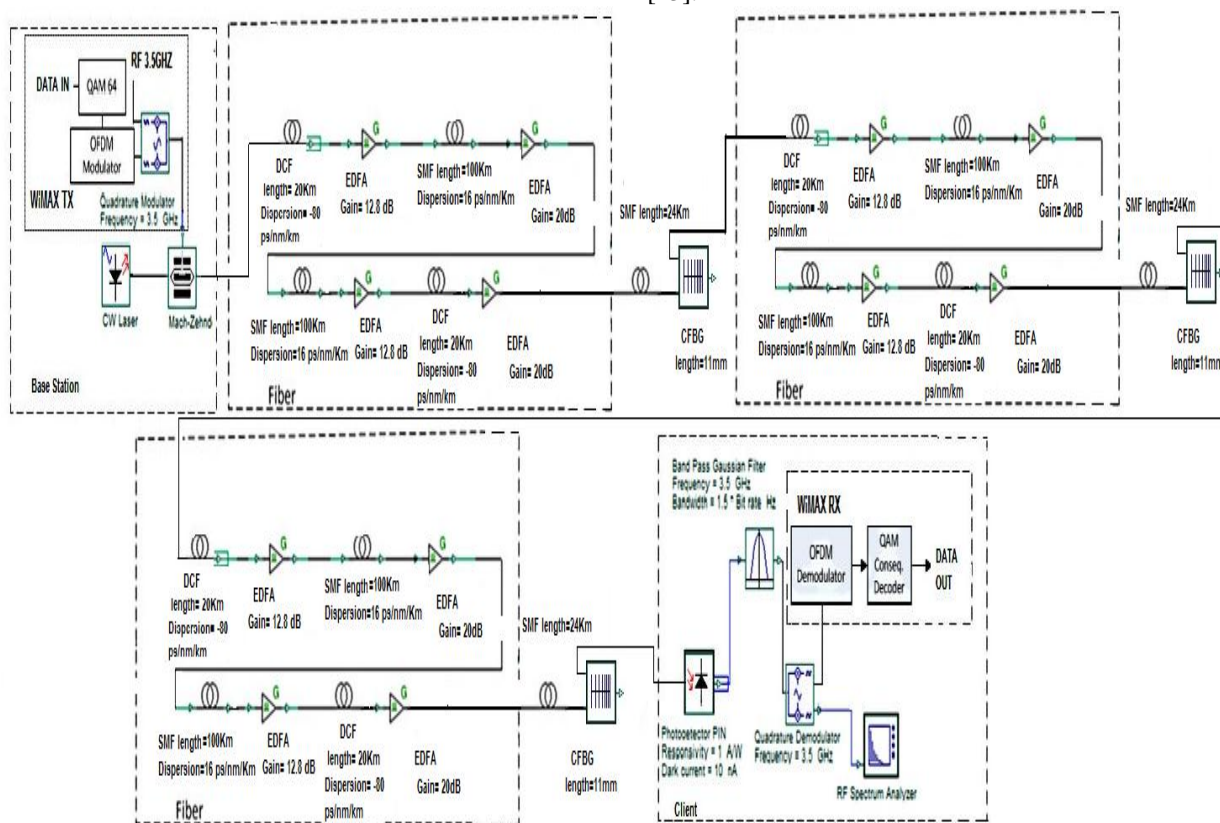

Figure 2. Schematic shows the setup of WiMAX downlink integrated in the RoF system which consist of SMF, DCF and CFBG for the increased fibre length of 792km.

OFDMA utilized in mobile WiMAX is scalable in the ability that by flexibly adjusting FFT sizes and channel bandwidths with fixed symbol duration and subcarrier spacing, it can address wide spectrum needs in different area regulations in a cost competitive approach. The S-OFDMA consists of a flexible and large fast Fourier transform (FFT) size changes from 128 to 2048, and it is used in IEEE802.16e-2005 [3].

The transmitter's (TX) source data in the WiMAX are encoded, and then modulated by QAM64, buffered and manipulated through serial to parallel (S/P) mechanism so as to make an appropriate vector for IFFT. The signal is transmitted to the fibre as a RF signal; subsequently, converted to an optical signal by the RAU antenna by being indirectly modulated through the MZM. Intensity modulators are important components for high bit rate light wave systems operating at a wavelength of 1552nm.

The MZM structure is composed of an input optical branch, where the incoming light is split into two arms, and two independent optical arms, which are subsequently recombined by the output optical branch. As shown in Figure 3, the continuous wave (CW) laser diode (LD) emits a light wave into an optical input of the MZM; the WiMAX\_RF radiates into two electrical inputs of MZM. The bias voltage of  $V_1$ ,  $2_{bias} = V\pi/2$  controls the degree of interference at the output optical branch and accordingly the output intensity. The MZM is based on an electro-optic effect, the effect that in certain materials, e.g., LiNbO3, the refractive index  $n$  changes with respect to the voltage  $V$  applied across electrodes. The optical field at the output of the modulator is given by following equation [24]:

$$E_{out}(t) = \frac{1}{2} [exp(\frac{\pi}{V_{\pi}} V_1(t)) + exp(j \frac{\pi}{V_{\pi}} V_2(t))] E_{in} \quad (6)$$

where  $V_{\pi}$  is the modulation voltage, which is the differential drive voltage ( $V_1-V_2=V_{\pi}$ ) resulting in differential phase shift of  $\pi$  rad between two waveguides.  $E_{in}(t)$  is the optical field applied to the input of the modulator. The MZM modulated electrical signal refers to WiMAX-RF; optical beam

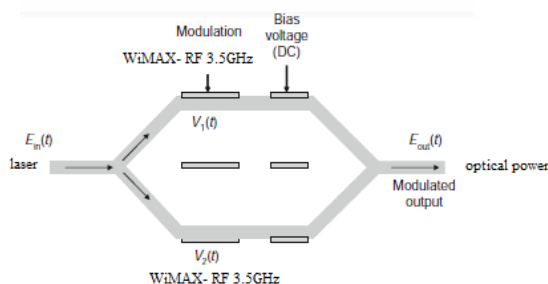

Figure 3. Schematic shows Mach-Zehnder LiNbO3 (MZM) optical input from laser diode CW and two electrical inputs from WiMAX\_Tx

refers to the CW laser and is injected in the output as an optical power signal over fibre. The CW LD technology is at the standard telecommunications wavelength of 1552.52 nm. The CW LD output power is too low and would require additional amplification. The CW LD has an average output power of 3 dBm for laser frequency 193.1 THz with a

linewidth of 10 MHz and relative noise dynamic of 3dB and a noise threshold of -100dB .

Subsequently, the optical signal is transmitted over the RoF system, which is composed of a triple symmetrical dispersion system: each consisting of DCF (20 km), SMF (100 km) SMF (100 km) and DCF (20 km), connected to the SMF (24 km) and to the CFBG, which is added after every 264 km. This setup allows a compensation of the positive dispersion signal in SMF; therefore, the signal transmission is increased to 264km fibre length.

The SMF dispersion parameter is 16 ps/nm/km and the SMF length is set up to 100km; the SMF signal attenuation is 0.2dB/km; therefore, total accumulated dispersion is  $16 \times 100 = 1600$  ps/nm. The dispersion slope will be sharper with the increment of the transmitting fibre length  $L$  as expressed in Eq. (2). DCF is configured to negative dispersion -80ps/nm/km at 1552nm to compensate the positive signal dispersion in SMF, considered in Eq. (7). It is proved to be effective to reverse chromatic dispersion in high-velocity light and it is highly important to increase the signal transmission distance and bit rate by a DCF function to keep the wavelength at a zero dispersion, which is called the "zero-dispersion wavelength" ( $\lambda_0$ ).

$$(D_{smf} \times L_{smf}) + (D_{DCF} \times L_{DCF}) = 0 \quad (7)$$

where  $D_{smf}$  is the dispersion factor in the SMF,  $L_{smf}$  is the fibre length of the SMF,  $D_{DCF}$  is the dispersion factor in the DCF and the  $L_{DCF}$  is the length of the DCF.

$$\left(\frac{16ps}{nm}/km \times 100km\right) + \left(-\frac{80ps}{nm}/km \times 20km\right) = 0 \quad (8)$$

Eq. (8) shows the result of the accumulated dispersion in combined DCF and SMF. SMF is configured to a fibre length of 100km and DCF is configured to the negative dispersion of -80ps/nm/km and used over a 20km fibre length to reduce the chromatic dispersion and, as explained before, DCF is added to keep the transmission signal of zerodispersion for a long distance.

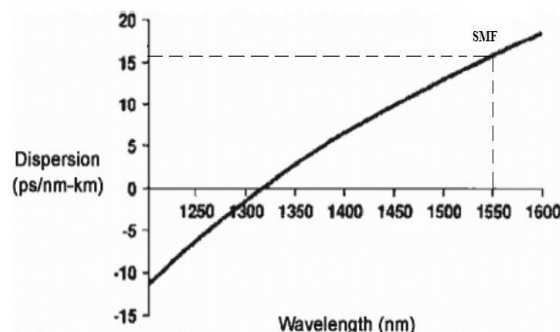

Figure 4. Illustrates the dispersion character for the wavelength

As shown in Figure 4, the dispersion of the light signal in fibre optic is zero by 1330nm and 16 ps/nm/km by 1550 nm wavelength. The advantage of using a wavelength of 1552nm compared to a wavelength of 1330nm lies in low power attenuation. The devices working with the 1330 nm wavelength are able to transmit a high amount of power but the modulation constraints of the laser source can make the design more complicated. The wavelength of 1550nm is the most used in terrestrial communication systems and a wide range of devices are available[25]; the Doppler Effect is lower than at other frequencies and for this carrier it is possible to carry out DPSK (Differential Phase Shift Keying) and QAM modulation schemes.

Figure 5 illustrates the affected DCF of the signal dispersion in SMF; the signal transmitter TX injects the WiMAX RF in the fibre after modulation through the laser diode and MZM. In the fibre system the SMF is configured for a fibre length of 100km because of the SMF's dispersion character of 17ps/nm/km at 1552nm, the 20km DCF is added and configured to the negative dispersion of -80nm/ps/km to keep the transmission signal of zero dispersion.

As described in Section III, the DCF has a high-power attenuation and cannot be used in this system for a distance longer than 20 km; therefore, the EDFA is employed after 100km of SMF, being configured to 12.8 dB. The CFBG

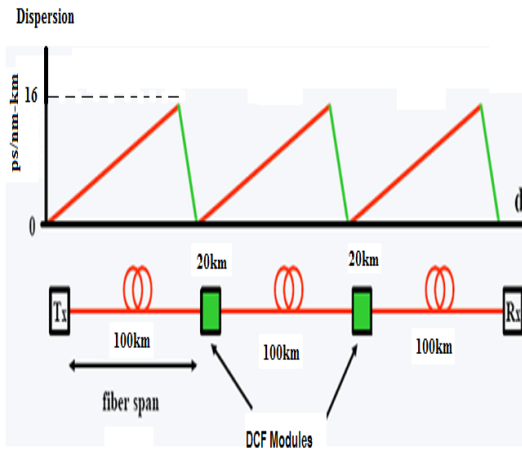

Figure 5. Illustrates that for every 100km SMF fibre length there are 20 km long DCF modules to compensate the accumulation dispersion in the SMF.

chirped bandwidth is  $\Delta\lambda=2$  nm;  $n=0.0006$  and lengths of 110 mm. The optical power is converted to the current electrical signal by a photo detector diode (PIN for dark current 10nA and centre frequency 193.1 THz). The electrical bandpass Gaussian filter is used to minimize the electrical signal noise and group delay becomes constant for all frequencies. In a receiver, a bandpass Gaussian filter allows signals within a selected range of frequencies to be heard or decoded, while preventing signals at unwanted frequencies from getting through the centre frequency ( $f_0$ ). As mentioned before,  $f_0$  is set up to 3.5GHz for a bandwidth of 20MHz.

The applied RAU antenna can offer a small antenna size for broadband operation. The RAU can convert the incoming RF signal to the fibre and subsequently to an electrical signal. The incoming optical signal is detected by a photodiode (PD) and converted to the RF signal, then amplified and transmitted over the wireless path for 300m to the BS antenna and to the WiMAX RX. At the WiMAX receiver the RF signal is demodulated by the Quadrature demodulator, which implements an analog demodulator using a carrier generator for Q and I Quadrature components; it consists of two low pass filter. 7GHz cutoff frequency of low pass filter is configured; the OFDM demodulator is implemented by a complex point 1024 FFT; in OFDM the FFT is used to realize multi-carrier modulation, which reduces the complexity of OFDM systems greatly. Generating OFDM symbols with high data rate requires a high-speed FFT processor. Moreover, an FFT processor with low area and low power consumption is needed by the portable feature of OFDM systems. In the QAM sequence decoder, the bit sequence is split into two parallel subsequences; each can be transmitted in two quadrature carriers when building a QAM modulator. This is achieved by using a serial to parallel converter.

## V. RESULT AND DISCUSSION

The simulation results clearly show that the fibre attenuation and the chromatic dispersion, which are the main cause for a limited signal transmission length and data bit rate in the RoF, can be controlled by transmitting the WiMAX-OFDMA for 120 Mbps bit rate via a combination of different fibers, namely SMF, DCF and CFBG. The results indicate that the use of an accumulated dispersion compensation method, which consists of a triple symmetrical compensator system and, in addition, a CFBG for each system, is the means to control the chromatic dispersion, keep the transmission signal of zero dispersion and to increase the transmission distance to 792 km.

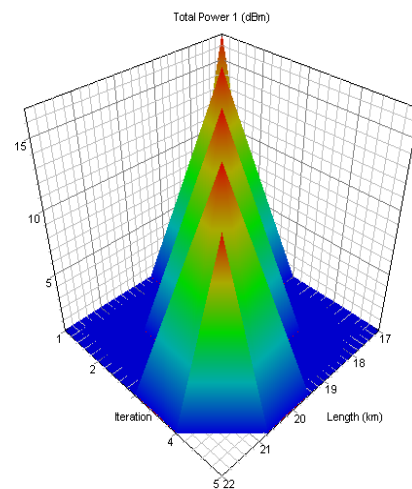

Figure 6. Illustrates the total power dBm in the DCF for a DCF length from 17 to 22km and the wavelength is 1552nm

Figure 6 shows the total of the signal power in dBm according to the DCF length from 17km to 22km. At 17km, the signal power is 16.2dBm; at 22km, the signal power is 8dBm, due to the high signal power loss the CFBG and the EDFA are used. The red colour refers to the optical power, the power is focused in the centre of the fibre and the green colour refers to the noise in the DCF, which is caused by the laser diode.

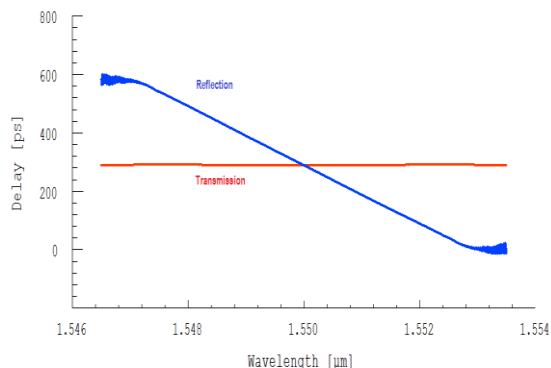

Figure 7. Illustrates the delay in the CFBG for the wavelength from 1546 nm (1.546μm) to 1554 nm (1.554μm); the delay is measured in ps.

Apart from the combination in the order of DCF-SMF-SMF-DCF-SMF with a fibre length of 20-100-100-20-24 km, a 55mm long CFBG is added at every 264 km to compensate the chromatic dispersion. Figure 7 shows the reflectivity and delay characteristics of the chirped gratings operating in 10-55mm grating length. It is noted that the reflection wavelength of 1548 to 1552 nm has the delay time of 50ps; respectively the delay in the CFBG is important to balance the wavelength and to control the chromatic dispersion, due to the different frequency velocities in the fibre.

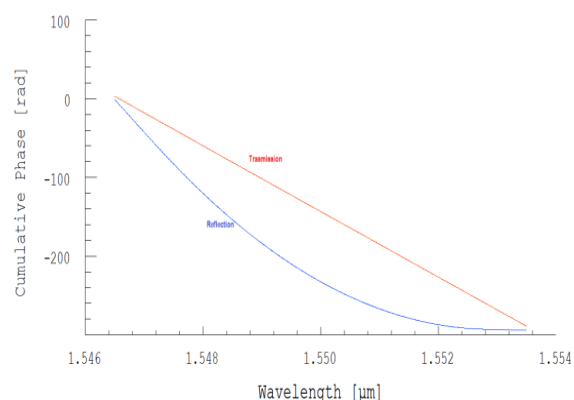

Figure 8. Shows the cumulative phase of the transmission and reflection wavelength.

The control of the chromatic dispersion is essential in the fibre optic system network, due to the increase of the signal transmission distance, as well as the data bit rate. The CFBG can be implemented in DWDM and in this research is used as signal tuneable. The cumulative phase difference between

transmitted and reflected wavelength is shown in Figure 8. The blue line refers to the reflective wavelength in the CFBG and the red line represents the forward wavelength transmission. Any delay in the wavelength in the CFBG refers to phase delay 75ps at wavelength 1552nm.

TABLE I. OSNR INPUT AND OUTPUT

	Input Signal dB	Input OSNR (dB)	Output Signal (dB)	Output OSNR(dB)
CFPG 10mm	-0.06141464	99.9856	-8.5112	26.63
CFBG 32mm	-0.0141464	99.9856	--11.2111	23.62
CFBG 55mm	-0.06141464	99.9856	-13.4115	19.62621
	(nm)	(nm)	(nm)	(nm)
Wavelength	1552.5244	1552.524	1552.52	1552.524

As mentioned in Sections I and III, the wave delay in the CFBG is important because the light spectrum in SMF and DCF travels with different velocity, which means that it consists of different wavelength, which reaches the end of a fibre optic cable delayed. Therefore, the CFBG is used to control the chromatic dispersion and power attenuation, as well.

Table (I) shows the input parameter at transmitter after MZM and the output parameter after 792km. The WiMAX-RF modulated to laser for frequency 193.1THz for a wavelength of 1552.5244nm. The difference between the input OSNR and output OSNR ranges at ~ -74dB; if the chirped gratings are set up to 10mm, the input signal power is at -0.0614 dBm and the output signal power is at -8.5112 dB. The difference between input and output power is - 8.4498 dB, when the chirped grating of CFBG is 10mm for a fibre length of 792km. The result is highly satisfying because the optical amplifier only used 192 dB for the fibre length of 792km.

As shown in Figure 9, the configuration of the CFBG chirp length has an influence on the OSNR: the shorter the chirp length the higher OSNR. The higher output OSNR after 792km is 26.63dBm, when the chirp grating is set up to 10mm length, and lower OSNR, when the chirped grating is set up to 55mm. Additionally, the figure shows that the OSNR has decreased linearly, which is an important result because it let the signal in a stable condition and the signal quality is affected positively. This means, that the configuration of the CFBG can improve the signal quality in the RoF system and can be used as a band pass filter and tuneable component, as well.

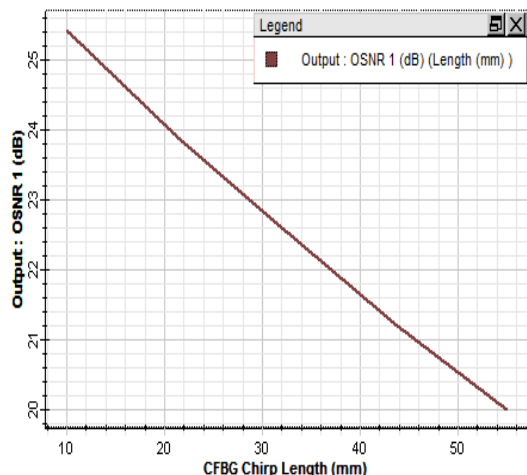

Figure 9. OSNR measurement at the Chirped Grating length from 10mm to 55mm in CFBG

As shown in Figure 10, the total gain power measured at CFBG chirp length from 10mm to 55mm at wavelength 1552nm decreases linearly. At a chirp length of 10mm the power is -8.5112dB, at 32mm -11.2111dB and at 55mm, the power is 13.4115 dB.

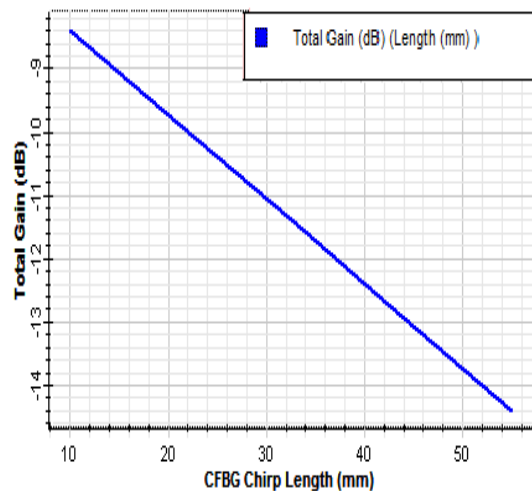

Figure 10. Total power measurement at the chirped Grating length from 10-55mm in CFBG

Figure 11 (A) shows the optical bandwidths for a fibre length of 264 and 792km at a wavelength of 1552nm. At all fibre lengths, the optical bandwidth is 300nm. There is a minor change in the optical signal power after the signal has travelled for 528 km: at 264 km, the signal power is -5 dBm, at 792 km the signal power is -14 dBm; however, a limited optical amplifier was used. The green area refers to the noise, which is produced by the laser diode, and the red area refers to the optical bandwidth, which is expressed in terms of wavelength rather than frequency, using the following equation [26]:

$$B_{\lambda} = \frac{\lambda^2}{c} B_0 \quad (9)$$

where  $B_0$  optical bandwidth is for wavelength 1552nm;  $c$  is light speed;  $\lambda^2$  is the wavelength square.

Figure 11 (B) shows the optical bandwidths for a fibre length of 792km at a wavelength of 1552nm. At all fibre lengths, the optical bandwidth is 300nm. The intensive green colour at 1552nm (1.55um) refers to the noise intensity in the bandwidth. The red colour refers to the signal power at -25dBm.

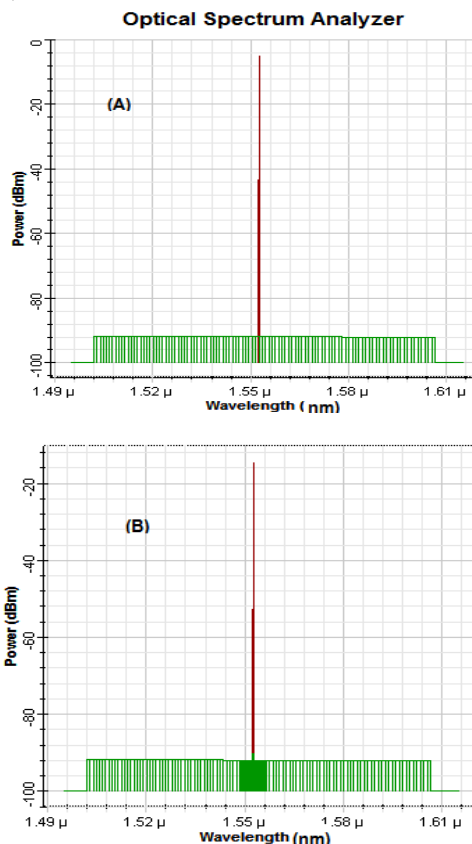

Figure 11. (A) optical bandwidth for fibre length after 264km (B) optical bandwidth after 792km fibre length

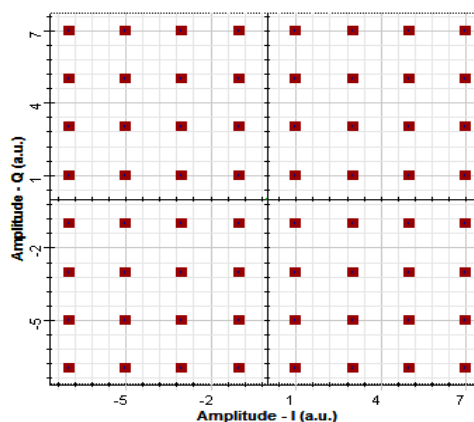

Figure 12. Constellation diagram of 120-Mbit/s WiMAX QAM-64 transmission downlink for fibre length 792Km



Figure 12 shows a constellation diagram, which is a representation of a signal modulated by a digital modulation scheme. It clearly shows the electrical constellation at the WiMAX transmitter which is a representation of 6 bit-data per symbol of the 64-QAM modulator, of WiMAX TX for OFDM 1024 and modulator 64- QAM 8 bit by SNR 116.78 dB; the signal is clear and noise free.

Figure 13 shows the electrical constellation diagram at WiMAX-TX receiver. The signal at the receiver is transmitted over RoF via the combined SMF and DCF for a length of 528km. The DCF length is 4x20km and the SMF length is 4x100km, respectively 2x24km. Compared to Figure 11, a change in the 6 bit QAM 64 can be recognized because of noise and power attenuation, which are added to the signal through the wavelength deployed over a distance of 528km in the fibre. The black colour refers to the noise and the red colour refers to the total signal.

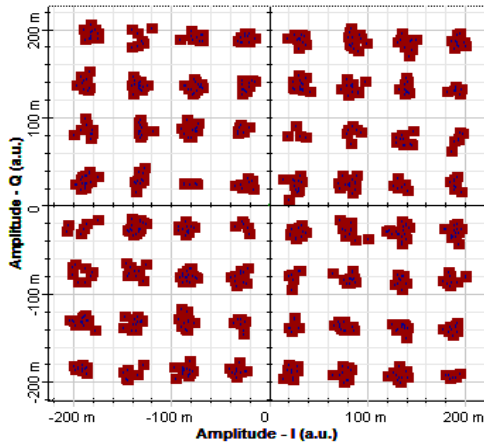

Figure 13. Constellation diagram of 120-Mbit/s WiMAX QAM-64 receiver downlink for fibre length 528Km

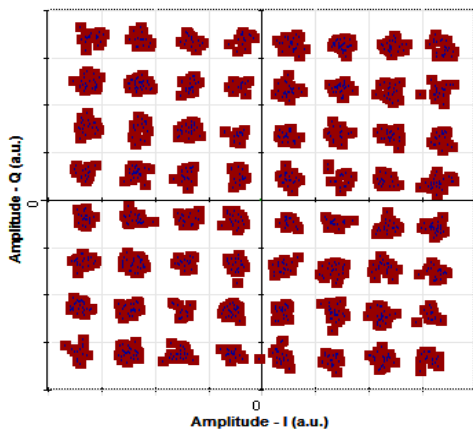

Figure 14. Constellation diagram of 120-Mbit/s WiMAX QAM-64 received downlink for fibre length 792Km

Figure 14 illustrates the electrical constellation diagram 64QAM for 6 bit at the receiver after the WiMAX transmission signal travelled over a fibre length of 792km

and was converted to an electrical signal by the photo detector diode. The signal has a noise, which is shown in blue, due to the laser diode noise; the red colour refers to the WiMAX signal total signal. The comparison of Figure 12 and Figure 13 shows that the noise has slightly increased by the extended signal transmission distance from 528km to 792km. The reason for this is the long transmission distance; the signal power becomes weak due to the laser noise and the DCF attenuation. To reduce these effects, an increase of the optical power amplifier is needed. This result shows the maximum signal transmission distance for a limited fixed power amplifier.

Figure 15 shows the RF spectrum of WiMAX 3.5 GHz carrier frequency for bandwidth 20 MHz at the WiMAX transmitter before transmitting over fibre, the bandwidth is in the frequency range of  $f_0-f_L, f_0, f_0+f_H$  (3.5-3.49, 3.5, 3.5+3.51) GHz, the spectrum of the signal power, displayed in blue, measured at 100 dBm and the green colour refers to the noise, which is measured as 22 dBm.

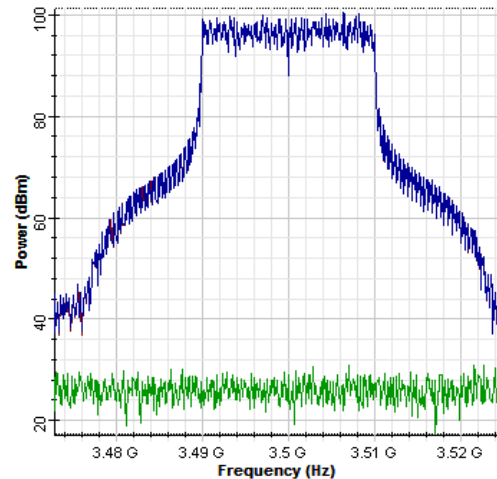

Figure 15. 3.5GHz WiMAX-TX for bandwidth 20MHz and FFT 1024 before transmitting over RoF .

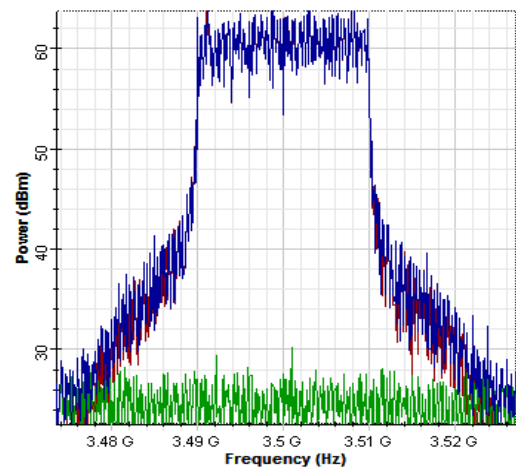

Figure 16. WiMAX carrier frequency 3.5GHz for bandwidth 20MHz at WiMAX-RX after transmission over RoF for fibre length of 792km.

Figure 16 shows the 20MHz bandwidth after a fibre length of 792 km for an output power of 60dBm; the noise is measured as 26 dBm. The spectrum consists of the signal and noise, which is illustrated in blue and the red area refers to the signal without noise.

The power loss between the transmitter and receiver is 30dBm. The signal is deployed over SMF, DCF and tuned by a CFBG filter for fibre length 792km. At the end of the 792 km fibre length, the optical to noise ratio (OSNR) is 26.64 dB. Typically, the larger the OSNR value, the lower the receiver sensitivity.

Table (II) shows the parameter at the electrical transmitter at electrical input of MZM; the maximum value of SNR is 116.78512 dB for WiMAX\_RF 3.5GHz; the total power is 16.785116 dBm.

TABLE II. TOTAL POWER AND SNR AT TRANSMITTER

	Total Power (dBm)	Signal Power (dBm)	Noise Power (dBm)	SNR (dB)
Min value	-100	-100	-100	0
Max Value	16.785116	16.785116	-100	116.78512
Ratio max/min	116.78512	116.78512	0	116.78512
	(Hz)	(Hz)	(Hz)	(Hz)
Frequency at min	0	0	0	0
Frequency at max	3.5e+009	3.5e+009	3.5e+009	3.5e+009

Table (III) shows the parameter of the electrical signal after having been converted from optical at the photo detector diode; the SNR is 31.318564 dB; the difference between input and output is 85.466556 dB; considering the WiMAX signal has been transmitted over a fibre length of 792km, this result is highly satisfactory

TABLE III. TOTAL POWER AND SNR AT THE RECEIVER

	Total Power (W)	Signal Power (W)	Noise Power (W)	SNR (dB)
Min value	23.26439e-015	0.39134784e-024	23.26439e-015	0
Max Value	0.13552317e-009	0.13547414e-009	49.022992e-015	31.318564
Ratio max/min	5825.3479	346.17323e+012	0.47456081	31.318564
	(Hz)	(Hz)	(Hz)	(Hz)
Frequency at min	50e+006	50e+006	50e+006	50e+006
Frequency at max	3.5e+009	3.5e+009	3.5e+009	3.5e+009

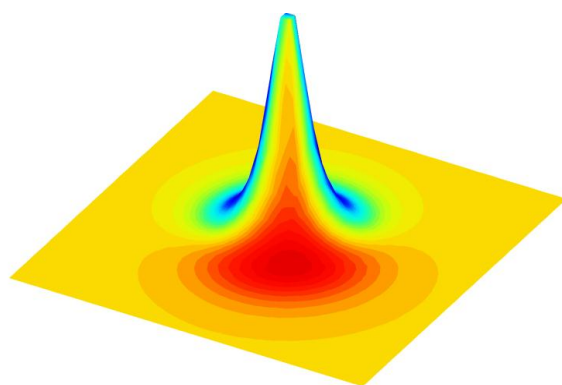

Figure 17. Signal transmitted in SMF for fibre length of 264km

Figure17 shows an optical signal transmitted over SMF fibre; the red colour refers to the optical power, which is to be seen clearly in the centre of the SMF after 264km fibre length.

The SNR is measured as 31.31856 dB at the receiver in comparison to the SNR of a WiMAX transmission signal over air, which is typically 21dB for a code rate of 3/4 [20]. The BS-TX propagation loss via air according to the Egli calculator[26] ranges at 167.57 dB for 5km. Compared to the transmission of the signal over fibre, which has travelled 792 km, using a laser diode of 5 dBm for fibre attenuation 180dB per 792km (SMF+DCF) attenuation, the result is highly satisfactory.

## VI. CONCLUSION

This paper proposed a method for transmitting RF signals over fibre, using a WiMAX system downlink deployed via SMF/DCF and CFBG over a RoF system. The system is able to carry a WiMAX S-OFDMA signal of 128 subcarriers with an FFT of 1024 for a 3.5GHz carrier frequency and bandwidth of 20MHz. The bit rate for WiMAX increased to 120Mbps with 64-QAM over a RoF system for a fibre length of 792km. We compared the chirp length 10mm to 55mm in CFBG with OSNR and proved the best OSNR result with 10mm chirp. The results show that by using SMF with a DCF setup for dispersion of -80 and a CFBG setup for a length of 10 to 55mm, we achieved an increase in the WiMAX transmission over fibre distance to 792km. This method is able to control the chromatic dispersion affected in the fibre. This means that the power budget of the WiMAX downlink signal can be improved compared to the energy consumed in a WiMAX transmission BS antenna 167.57dB for 5 km; the data bit rate increased to 120Mbps. Finally, the bandwidth spectrum stayed relatively constant over the long fibre distance, and the result of SNR and OSNR are highly satisfactory; the power consumption is very low between the input and output of the fibre.

In summary, with the described setup, we reached the aim to increase the transmission distance, to improve the frequency spectrum and to reduce the power consumption. Additionally, as future work, it is possible to further increase the signal transmission distance for various mobile and fixed broadband systems, such as the WiMAX and UWB system by utilizing more than three circuits, consisting of the triple symmetrical dispersion system SMF, DCF and CFBG.

## REFERENCES

- [1] M. Al-Noor, K.-keong J. Loo, and R. and Comley, "120 Mbps Mobile WiMAX Scalable OFDMA Signal Transmission over RoF with SMF, DCF and Chirped FBG for Fibre Length of 792 km," *ICWMC, 2010 6th International Conference*, IEEE Computer Society, 2010, pp. 373-377.
- [2] D. Pareek, *The Business of WiMAX*, Southern Gate, Chichester, west sussex: John Wiley & Sons, Ltd, 2006.
- [3] WiMAX Forum, "Mobile WiMAX, Part I: A technical overview and performance evaluation," June 2006.

- [4] A.N. oma Ng, Radio-over-Fibre Technology for BroadBand. Wireless Communication Systems door, Eindhoven: CIP-data Library Technische Universiteit Eindhoven, 2005.
- [5] J. Ma, J. Yu, X. Xin, C. Yu, and L. Rao, "Optical Fiber Technology A novel scheme to implement duplex 60-GHz radio-over-fiber link with 20-GHz double-sideband optical millimeter-wave transmitted along the fiber," *Optical Fiber Technology*, vol. 15, 2009, pp. 125-130.
- [6] I. Harjula, et al., "Practical issues in the combining of MIMO techniques and RoF in OFDM/A Systems," 7th WSEAS Int. Conf. on Electronics, Hardware, Wireless and Optical Communications, Cambridge, pp. 244-248, 2008.
- [7] D. Wake, N.J.G. Anthony Nkansah, C. Lethien, C. Sion, and J.-P. Vilcot, "Optically Powered Remote Units for Radio-Over-Fiber Systems," *Lightwave Technology*, vol. 26, 2008, pp. 2484-2491.
- [8] J. Ma, J. Yu, X. Xin, C. Yu, and L. Rao, "Optical Fiber Technology A novel scheme to implement duplex 60-GHz radio-over-fiber link with 20-GHz double-sideband optical millimeter-wave transmitted along the fiber," *Optical Fiber Technology*, vol. 15, 2009, pp. 125-130.
- [9] L. Chen, J. Lu, J. He, Z. Dong, and J. Yu, "A radio-over-fiber system with photonic generated 16QAM OFDM signals and wavelength reuse for upstream data connection," *Optical Fiber Technology*, vol. 15, Jun. 2009, pp. 222-225.
- [10] X. Jin-ling, H. Xu-guang, and T. Jin, "A full-duplex radio-over-fiber system based on a novel double-sideband modulation and frequency quadrupling," *Optics Communications*, vol. 283, 2010, pp. 874-878.
- [11] Y. Chaba and R.S. Kaler, "Comparison of various dispersion compensation techniques at high bit rates using CSRZ format," in *Optik - International Journal for Light and Electron Optics*, vol.121, 2010, pp. 813-817.
- [12] H. Yin and D.J. Richardson, "Optical Code Division Multiple Access Communication Networks Theory and Applications," Tsinghua University Press, Beijing and Springer-Verlag GmbH Berlin Heidelberg, 2007.
- [13] F. Martínez, J. Campos, A. Ramírez, V. Polo, A. Martínez, D. Zorrilla, and J. Martí, "Transmission of IEEE802 . 16d WiMAX signals over radio-over-fibre IMDD links," Project TEIDE FIT-330210-2006-86 and European Network of Excellence ISIS, pp. 1-9.
- [14] M.-li Yee, A. Ng, and M. Sauer, "Performance Analysis of IEEE 802 . 16e WiMAX Radio-over-fiber Distributed Antenna System," *Power*, 2009, pp. 197-200.
- [15] S.-J. Tzeng, H.-H. Lu, W.-I. Lin, H.-C. Peng, S.-S. Hsu, and H.-W. Wang, "A hybrid radio-on-DWDM transport system for PHS/LAN/ITS/WiMAX applications," *Optical Fiber Technology*, vol. 15, Mar. 2009, pp. 119-124.
- [16] H.-han Lu, C.-yi Li, S.-jye Tzeng, H.-chun Peng, and W.-i Lin, "Optical Fiber Technology Full-duplex radio-on-fiber transport systems based on main and multiple side modes injection-locked DFB laser diode," *Optical Fiber Technology*, vol. 15, 2009, pp. 251-257.
- [17] A.V. Osadchiy, K. Prince, and I. Tafur Monroy, "Converged delivery of WiMAX and wireline services over an extended reach passive optical access network," *Optical Fiber Technology*, vol. 16, Jun. 2010, pp. 182-186.
- [18] R. Kashyap, *Fiber Bragg Gratings*, Academic Press, San Diego, 1999.
- [19] G.P. Agrawal, *Fiber- Optic Communication Systems*, New York , USA: John Wiley & Sons, Inc., 2001.
- [20] Marcos D. Katz VTT, Frank H.P. Fitzek "WiMAX Evolution Emerging Technologies and Applications" Chichester, West Sussex, P Wiley & Sons 2009. Pp. 115-127.
- [21] M.D. Katz and F. H.P.Fitzek, *WiMAX Evolution*, west Sussex, UK: John Wiley & Sons, Inc., 2009.
- [22] Fazel, K, and S Kaiser. *Multi-carrier and spread spectrum systems*. John Wiley & Sons, 2003
- [23] S. Han, W. Yue, and S. Smith, "FTTx and xDSL: A Business Case Study of GPON versus Copper for BroadBand Access Networks," submitted to FTTH Conference paper to be published, 2006.
- [24] B.Chomycz, *plannig Fiber Optical Network*, New York, USA: MG Graw-Hill, 2009.
- [25] I.P.Kaminow and T. LI, *Optical Fiber Telecommunications IVA Components*, Jamestown Road, London: AP Academic Press, 2002.
- [26] <http://www.radius.net/egli--free-space-calculator.html> ,17.05.2011.