

A Hardware and Software System for Information Interchange in Multinational Disaster Relief Operations

Peter Dorfinger, Ferdinand von Tüllenburg, Georg Panholzer, Thomas Pfeiffenberger

Advanced Networking Center
Salzburg Research Forschungsgesellschaft mbH
Salzburg, Austria

e-mail: {peter.dorfinger, ferdinand.tuellenburg, georg.panholzer, thomas.pfeiffenberger}@salzburgresearch.at

Abstract—Information and communication technology becomes more and more important for large scale disaster work as it allows for sharing information between stakeholders in short times. However, the interchange of disaster related information is often affected by missing communication coverage and outages of pre-existing infrastructure. Further problems arise, if multiple organizations from different countries shall share all their disaster related information. Until now, there is no ICT-System available for disaster relief work, which provides an integrated solution of communication technology and information sharing and visualization applications helping for creating a common understanding across national and organizational borders of what is happening in the disaster operation. In this paper a flexible infrastructure for information interchange of disaster related information is presented. The first main building block of this infrastructure is the disaster information system consisting of various IT systems and software applications used to produce, share and manage disaster data. The second building block is a mobile, and easy to handle 802.11 driven communication hardware and software system. This system is capable to bring communication coverage to almost every arbitrary location within a disaster area by setting up a meshed wireless network. The wireless network is used to connect end devices used by field personnel to the disaster information system. The communication system can be operated independently of any pre-existing infrastructure such as Internet access or power supply. Several training events showed the usability of the proposed solution and the advantages of a comprehensive ICT system in international disaster work.

Keywords—Emergency network; 802.11 communication; interoperability; information interchange; disaster relief.

I. INTRODUCTION

One central problem when coordinating relief units in large scale disaster relief operations is to provide the right information to the right people. Especially in the context of international relief operations new coordination problems arise from differing structures of the international associations. Different languages causing communication difficulties and making information distrustful if not properly formulated information is leaving room for interpretation. An example for the impact of this problem is the earthquake disaster in L'Aquila, Italy. Here, the local authorities declined offered international help as the effort to integrate

foreign relief organizations in their own relief work was considered as too high, requiring too much manpower urgently needed in other places in the disaster area.

Information technology can prove extremely useful in information gathering, storing and sharing. However, it must be kept in mind, that information should be shared according to the principle "as much as necessary, as little as possible" in a way easily and clearly to understand in order to protect helpers from information overload. With the help of broadband communication technology the narrow information channels of radio messages or telephone calls could be prized by enriching transported information with videos, photos or sensor data. Experiences from the usage of such a system by end users in multinational disaster operations are presented in [1]. Within this paper we present in detail the technical framework behind such a broadband communication solution.

Following the principle of sharing precise and comprehensive information to the right person has multiple advantages to enhance efficiency of disaster relief work. First, it prevents helpers from becoming overwhelmed by the volume of information transmitted by e-mails, radio messages and telephone calls – a fact that is often claimed by relief workers nowadays [2]. Second, correct decisions can be made more quickly in order to provide urgent needed aid to affected people. For example, by bringing all meaningful information to a team leader working in the field, the team leader could take the right decision autonomously [2].

This is where the IDIRA (interoperability of data and procedures in large-scale multinational disaster response actions) project [3] comes into the picture. IDIRA's target is to enhance interoperability of organizations and their systems in order to streamline the cooperation in relief work.

IDIRA addresses this interoperability topic twofold. First, at an organizational level, IDIRA examines possibilities to reach administrative coordination of multinational disaster relief organizations, each with their own workflows and procedures. Second, on the technical side, IDIRA provides a complete solution consisting of information systems, communication protocols, software applications, and standard data formats. The developed systems accompany the topics stated above: Bringing all meaningful information to exactly the people needing it to make correct decisions and present information in an unambiguous manner.

This solution allows exchanging disaster related information between administrative operators, executive personnel, and other disaster management systems connected to IDIRA. With IDIRA, information on incidents, resources, observations, and sensor data should be collected and shared to various other information systems like mobile devices and command and control systems (C&C). To reach the required level of interoperability and automatic information exchange, IDIRA has a strong focus on mobility of the developed systems. It is necessary to bring the systems directly to the scene of the disaster, because of severe infrastructural damage after the disaster.

A prerequisite for an information exchange is a working broadband communication infrastructure within the disaster area. One of the major problems we address with our proposed communication infrastructure is that after a large scale disaster, the existing public broadband network is often partially destroyed, overloaded, or hit by power outages. Consequently, first responders cannot rely on any pre-existing infrastructure which may fail as a consequence of the disaster.

As the communication network is essential for a more efficient collaboration between first responders, there is a critical need for the fast setup of alternative communication means. However, first responders are not experts in setting up communication equipment. Thus, easy setup and maintenance is heavily required for such systems.

This paper will present an easy to install adhoc communication infrastructure for first responders to be used for an enhanced collaboration in large scale disaster operations.

This paper is structured as follows: Section II presents technologies and standards used within IDIRA and gives a brief overview on alternative communication solutions for disaster operations. Section III describes the IDIRA information system, as an example for an enhanced information system useable in multinational disaster operations. Section IV presents the details of our proposed mobile communication solution. Section V concludes the paper and outlines further steps and ideas to improve our solution.

II. RELATED WORK

Within the IDIRA applications, disaster information is represented using the Emergency Data Exchange Language (EDXL) [4]. This is an open XML-based messaging format and suite of standards aimed at the use of information exchange in emergency management systems. The EDXL-CAP (Common Alerting Protocol) [5] data format is applied to data about occurred incidents registered, for example automatically by a sensor system or manually by a human user. Information about resources such as availability of relief units, emergency vehicles or electrical generators, are exchanged by EDXL-RM (Resource Messaging) [5] standard. The EDXL-SitRep (Situation Report) [7] messaging standard is used within the IDIRA context for exchanging information on observations and situation reports sent by commanders in the field via their mobile devices. These standards are not bandwidth optimized and potentially

use large headers and large data payloads. Large scale disasters may result in thousands of such messages. Consequently, to transport this information a broadband communication infrastructure is needed.

Nowadays, a broad variety of communication technologies are used by first responder relief organizations and the most widespread technology used for many years was standard voice radio. However, with the advent of mobile communication standards such as 2G, 3G, and 4G these technologies are increasingly displaced. There also exists technology that is more tailor-made to disaster relief organizations regarding mobility and independence of pre-existing infrastructure such as working backbone networks and power supply. This makes sense as, for instance, mobile phone networks are often heavily overloaded or partly out of order after a disaster occurred. One approach to overcome these problems was TETRA [8]. TETRA allows both, range limited direct device to device communication without usage of a fixed infrastructure and range unlimited indirect communication via a fixed infrastructure. To enhance reliability of TETRA, the fixed infrastructure system was designed in a highly redundant way and is not made accessible to the public. The downside of TETRA is the limited bandwidth (28.8 kbit/s) available for data communication.

Other communication solutions are based on satellite communication systems like BGAN [9], VSAT [10], or Emergency.lu [11]. Satellite communication is used for both data and voice communication and is operable also in remote areas. The disadvantage of this technology is the usually high operational costs and, in case of BGAN, the very limited bandwidth. With the exception of BGAN satellite communication seems as a central Internet uplink technology in the disaster area and less as a communication technology used by field personnel to communicate with each other.

Especially the limited or expensive data communication capabilities are making these technologies only usable to a restricted degree. IDIRA heavily depends on data exchange with higher bandwidth demands and limited latency. One example is user interaction via IDIRAs web interface - the so called Common Operational Picture (COP). Here, data are exchanged between web clients of tactical personnel at the Command & Control Center and field commanders. To bootstrap a device using COP an initial data download of about 10 Mbyte of data is necessary and for a seamless operation a bandwidth of about 2 Mbit/s is recommended.

Another problem arises from special international operating permissions and licenses needed for some communication technologies such as WiMAX [12] equipment. Moreover, for a communication system specifically designed for public protection and disaster relief (PPDR) called Highly Mobile Network Node (HiMoNN) [13] operating licenses are only available for a few countries worldwide. HiMoNN is designed in compliance with ECC Recommendation (08)04 [14], and operates with transmission power of 8W in the 5GHz frequency band. It is able to transmit data over a distance of several kilometers with a bandwidth of 28Mbit/s.

To overcome the problems of international operation permissions also other approaches were considered. For example, in the work of Raffelsberger and Hellwagner it is proposed to build up a mobile ad-hoc network (MANET) using the end user devices of first responders as communication hops [15]. These devices are using their 802.11 wireless network interfaces to build up connections to other devices. This approach overcomes problems with missing operation permissions as 802.11 equipment can be operated all over the world without special license. During operation, first responders sending data via this MANET to a central host located in the Command and Control Center also employing special routing protocols. However, a quite dense concentration of devices is necessary making it difficult to use this technology to bridge distances of several kilometers to reach the central host. Another approach [16] overcomes the problem of low device density by placing mobile devices as stationary relays. It achieves this by using the mobile devices of disaster survivors to set up a disaster recovery network using 802.11 Wi-Fi. In contrast to other discussed approaches it focuses on connectivity for the survivors instead of the rescue teams, but can be used for both. Their approach and ours can be combined for greater range and flexibility.

The communication system proposed in this paper also uses 802.11 [17], as this technology is widespread, cheap and can be used all over the world without special licenses. One of the main achievements of this work was to provide a solution for the problem of limited range between two 802.11 end points.

As routing protocol we use the Optimized Link State Routing Protocol (OLSR) [18], which is optimized for constrained wireless LANs. OLSR is based on multipoint relays in order to reduce the routing overhead on the network.

III. IDIRA DISASTER INFORMATION SYSTEM

In IDIRA, an information system is developed that improves information sharing and information presentation in disaster relief work. On the technical side, this information system consists of various software applications and specific hardware solutions allowing, for example, optimal resource planning and decision finding across national and organizational borders. This section gives an overview of applications and hardware infrastructure developed within IDIRA.

Various software applications were developed to support information collection, data analysis, decision finding, and information sharing and presentation.

One main building block of IDIRA's information system is the disaster information data store, a central system used for storing all information related to the disaster. The data store comprises of information about incidents and observations or sensor data. Furthermore, information about available resources in the field - such as positions, tasks and utilization is stored as well as geographic information about infrastructural facilities like hospitals. Also, other important information such as weather data is contained within the data store.

To store and transmit this information, standardized protocols and data formats are used, for example, the Emergency Data Exchange Language (EDXL) standardized by OASIS [4].

An example for automatic information collection and using EDXL is the sensor data integration. IDIRA supports automatically inducing data generated by different sensors using the OGC Sensor Observation Service (SOS) interface. IDIRA uses a generic Sensor Fusion Engine (SFE) for sensor data aggregation. In case of a pre-defined behavior is recognized, the SFE generates an alarm messages in EDXL-CAP format [19]. The EDXL-CAP is one specific message format defined by OASIS specifically for information interchange in disaster operations [5]. The standard CAP message contains information such as type of emergency, source of information, level of severity, location, and extent of disaster. A link to detailed information, such as state of damage and numbers of casualty for all settlements affected and, for example, coordinates of the nearest airports can be provided in the CAP message. Also, information related to availability and status of resources such as a fire fighting vehicle or some other technical equipment like water pumps is shared using EDXL. For this purpose, the EDXL-RM (Resource Messaging) [5] standard is used. The EDXL-SitRep (Situation Report) [7] messaging standard is used within the IDIRA context for exchanging information on observations and situation reports, e.g., generated by commanders in the field.

Several software applications were developed within IDIRA to insert, produce, share and process disaster data. To support optimal decision finding and risk management various simulation tools were integrated. For example, a fire simulation tool (FireSim) can be used to simulate the spread of forest fires [20] and a chemical accident simulation tool (ChemSim) is used to simulate the propagation of possibly toxic gases and chemicals. These simulators are mostly based on weather data such as wind strength and direction and several geographic parameters such as soil conditions and even more specific parameters such as dissolution rates of chemicals. An evacuation simulator can be used to calculate the safest way for evacuating people out of districts also considering geographic information and observations such as obstacles or dangerous areas. For improved resource allocation an optimal spatial partitioning algorithm was used [21].

Further decision support systems are integrated into IDIRA covering routing and load balancing capabilities. Using these applications feasible paths for vehicles or relief workers can be calculated. Also, questions can be answered such as which unit can reach a certain destination within a given amount of time, or which unit can be at the destination most quickly. Load balancing algorithms are supported, e.g., to distribute injured people optimally to medical facilities while preventing from overload.

One further application of IDIRA is the integrated reporting system. Using the reporting application reports can be generated containing all meaningful information depending on the person the report is generated for. This helps protecting relief workers from information overload.

Another useful application developed within IDIRA is missing person tracing. This application helps to match data of missed persons with data of rescued persons across different tracing systems.

Furthermore, a software interface exists in IDIRA, which allows creating connections to external applications like specialized management tools used by a certain unit or organization. Usually, for data exchange between IDIRA and the external application, a standardized message format such as EDXL is used. The IDIRA information system is designed to gather from and to provide information to local command and control infrastructures. For example, in case of earthquakes, the information of external agencies such as the German Geoforschungszentrum, the US Geological Survey or the European Mediterranean Seismological Center can be induced into the IDIRA information system.

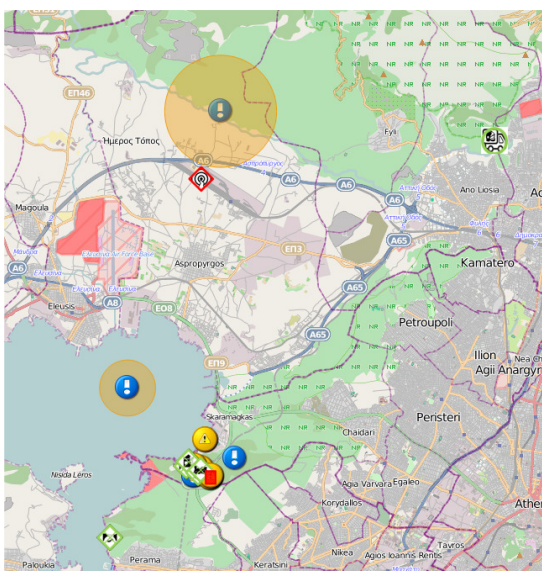

Figure 1: Disaster Information viewed by the COP.

The centerpiece of information presentation is the so called Common Operational Picture (COP). The COP is a web based application having its main goal to present all information in the system in an understandable and tailor-made way to the distinct users of the system, such as field commanders, tactical commanders, authoritative person or other stake holders within disaster relief work. Mainly, COP visualizes incidents, resources, tasks and other relevant information for disaster management on a map that can be seen in Figure 1. This map shows the epi center and affected regions of an earthquake, the position of resources or the location of incidents. Applying various filters and utilizing additional views on the available disaster information, COP helps to maintain an overview of the situation and protects from overlooking important details on a topic while simultaneously protecting the user from data overload. Furthermore, COP supports communication capabilities helping to get in touch with people involved in current relief work. Tasks can be assigned to field units, updates on tasks

can be communicated by field units, text messages can be sent, or voice calls initiated.

The COP and most of the applications introduced above are running on hardware infrastructures specifically designed for IDIRA. This includes the so-called Fixed Infrastructure and a transportable compound called Mobile Information and Communication System (MICS).

The Fixed Infrastructure is a cloud computing infrastructure intended for high availability operation. It is located in a data center and reachable from the disaster area with permission as soon as there is access to the Internet. The Fixed Infrastructure together with the applications it is hosting acts as a central information hub where all disaster related information is stored and all persons and devices in disaster relief actions can access these data. The advantage of such a central data hub is that all users have the same view on the current state of a disaster.

While the Fixed Infrastructure is only accessible when Internet uplink is available in the disaster area and the Fixed Infrastructure itself is not affected by the disaster, a transportable version of this central information hub was designed with the MICS. The MICS can be shipped directly on-site and hosts the same services applications as the Fixed Infrastructure and runs them locally at the disaster area. This makes the need of an Internet uplink optional and the system is fully functional in absence of it. Nevertheless, if an Internet uplink is present the MICS establishes a VPN connection to the Fixed Infrastructure that is running an OpenVPN server. For the uplink, any broadband communication technology existing at the MICS location can be used. Likewise the Fixed Infrastructure, the MICS provides access to external expert systems locally (or via Internet – if accessible).

The IDIRA information system is the central information hub where disaster related information is accessible for relief workers and authoritative personnel. The second crucial part of the system is the communication system that grants access to the IDIRA information system and allows transmitting all meaningful information to mobile devices of field operators in action and will be presented in the next section.

IV. IDIRA COMMUNICATION SYSTEM

The IDIRA communication system is intended to connect devices at command and control centers as well as mobile devices to the IDIRA disaster information system. The IDIRA communication system fulfils a series of requirements, either brought in by first responder organizations or having its basis in the design principles of IDIRA itself.

The following requirements are the results of end user surveys and a detailed requirement analysis done during the project:

(1) The first requirement regards a largely unlimited and almost worldwide valid operation permission of the communication system. This is necessary as it would be a time-costly process to apply for operation permissions after a disaster has struck somewhere in the world. (2) Furthermore, the system should allow for integrating locally existing (and functional) broadband communication networks into the

IDIRA communication system. (3) The usage of open standards should ensure that a broad variety of end devices can easily be integrated into the communication network being able to exchange data with the IDIRA disaster information system. (4) Usually, relief organizations only have a few IT experts. This entails the requirement that especially the field components of the communication system can be easily installed and handled (even by non IT experts). (5) One further requirement concerning especially end devices is basic offline functionality. When the connection to the information hub is interrupted, users of end devices must be able to work with the system without great limitations. (6) The last requirement regards the provided bandwidth of the communication system. The system must provide enough bandwidth to guarantee a seamless interaction with the information hub (i.e., at least 2 Mbit/s for operating the COP on a mobile device). These requirements are described in more detail in [1].

With regard to the requirements for international operating permissions and the usage of open standards, the mobile communication system has been designed to use 802.11 based network technology. Additionally, 802.11 technologies are widely spread nowadays, thus, does not require high acquisition and operating expenditures. On the other hand, two major drawbacks were needed to overcome:

- Relief forces are not experienced in setting up a 802.11 communication network and,
- 802.11 provides communication coverage for small areas only.

This section presents a communication solution for a transportable 802.11 based communication network, which is intended to be installed right after a disaster strikes, bringing communication coverage to almost every place within a disaster area and, additionally, is fulfilling the requirements stated above.

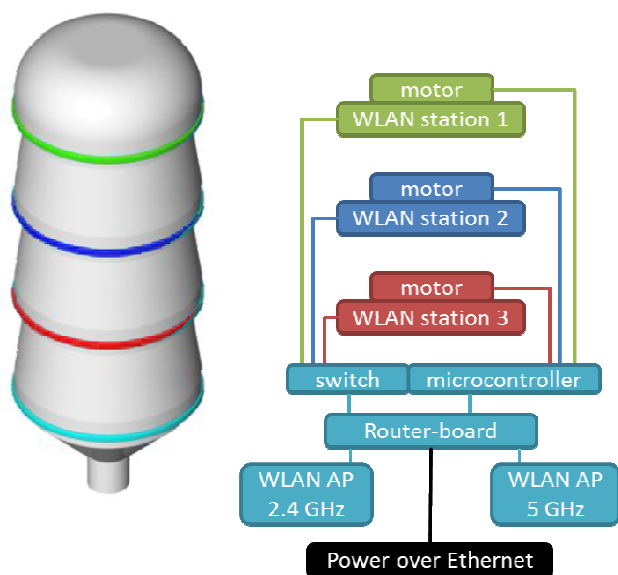

Figure 2: Schematic of the Wireless Gateway.

A. Mobile Communication Equipment

The central element of the proposed communication solution is a set of so called Wireless Gateway (WGW) devices.

The central ideas behind the WGW are that (1) multiple Wireless Gateways (WGWs) get automatically interconnected using directional antennas and 802.11 equipment. In comparison to omnidirectional antennas with directional antennas the signal quality between 2 WGWs can be improved. If two directional antennas are exactly aligned to each other the ratio between signal strength and noise level (SNR) increases and results in a higher possible throughput or larger distances between two WGWs. (2) After powering on, a WGW autonomously connects to other WGWs and starts building a meshed WLAN backbone network, which finally connects to the IDIRA disaster information system. (3) Additionally, each WGW provides communication coverage with a wireless hotspot and/or Ethernet LAN for end devices. (4) WGWs are designed as transportable devices and only need to be mounted on a pole and tripod before being powered on.

Following these 4 ideas, a system was designed that finally provides a solution for the two major drawbacks and the imposed requirements.

The main building blocks of the wireless gateway are presented as schematic in Figure 2. The system is mounted in a modular plastic housing consisting of four stacked layers. The top three layers (also referred to as modules) are equally built up. Each one is composed of a WLAN station, a directional antenna and a motor - all mounted on a turntable. The WLAN station supports wireless client mode and access point mode and is connected to a ~16 dBi directional antenna. The DC gear motor allows rotating the turntable by 360° on the horizontal plane. Keeping WLAN station, antenna and motor altogether on the turntable simplifies cabling of the devices and reduces the risk of entanglements when the turntable is rotating.

The bottom layer contains the control hardware and software of the WGW. A 5 port 100 Mbps Ethernet Switch connects the 3 top layer WLAN stations to a central router board containing the control logic, which is in charge of building the backbone connections to remote WGWs.

Figure 3 shows a schematic overview of the prototypes, which were developed based on this concept. The Router-board is an industrial grade embedded PC called Avila from manufacturer Gateworks. It is based on an Intel IXP425 CPU and features two 100 Mbit/s Ethernet ports and 4 MiniPCI slots. As operating system OpenWRT is running on the router board.

Furthermore, two out of the four MiniPCI slots of the router-board are equipped with CM9 MiniPCI WLAN cards from manufacturer Wistron NeWeb. The cards are based on Atheros AR5213A chips, one is operating in the 5 GHz band used for establishing the backbone connection between WGWs and the other operates in the 2.4 GHz band and is used for connecting end devices in the environment operated in the wireless cloud around the WGW.

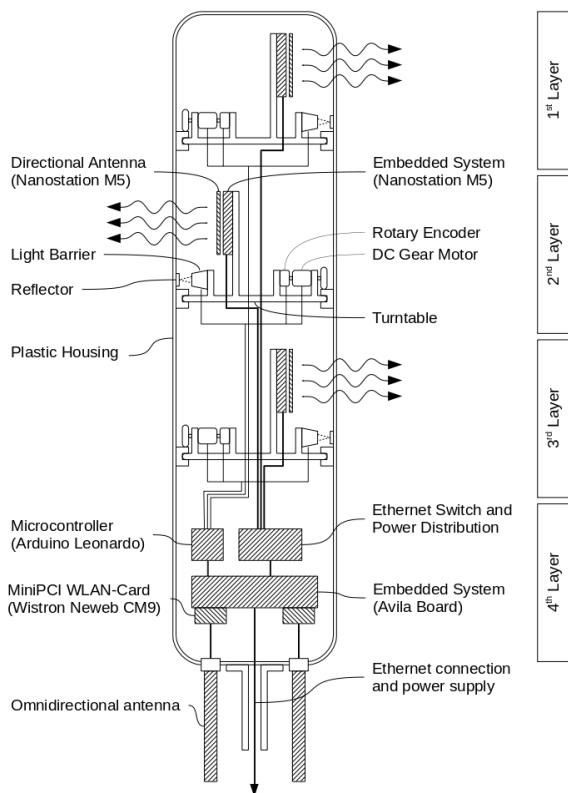

Figure 3: Prototype schematic overview.

The WLAN stations on the top three layers were implemented using a commercial product called Nanostation M5 from manufacturer Ubiquiti Networks [22]. For easier integration the plastic housing of the Nanostation M5 was removed and only the bare electronics were mounted on the turntables. To provide protection against physical influences the housing of the WGW covers all mechanical and electronic parts. The Nanostation M5 provides a built in 100 Mbit/s Ethernet interface used as data-link between the Nanostation M5 and the Router-board. The antenna inside the Nanostation M5 has a non-symmetrical radiation pattern of about 42° azimuth angle and 15° elevation angle. The devices are mounted 90° rotated so that the relevant radiation angle for the mechanical antenna alignment process is now the narrow 15° angle. The directional antenna is dual-polarized to support the MIMO feature of the 802.11n wireless interface. The installed MIMO antennas promise to enhance the signal quality and allow for higher bandwidth [23]. Figure 4 shows the radiation pattern of both polarization planes for the 15° beam width (green horizontal elevation, blue vertical elevation).

The Nanostations are configured to operate as router and run a modified Ubiquiti firmware supporting the OLSR routing protocol that is also used on the Avila router board. The OLSR configuration has been modified such that Ethernet links are generally preferred over wireless links.

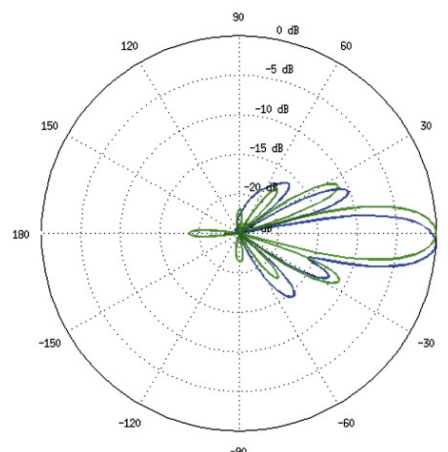

Figure 4: Nanostation M5 radiation pattern [22].

Additionally, an Arduino Leonardo microcontroller is connected to the router-board, which itself interfaces the motors of the top three layers to perform their rotation. The microcontroller tracks the position of each turntable by a light barrier. The light barrier is attached to the turntable itself together with a reflector attached to the outer housing of each layer. As soon as the light-barrier reaches the reflector the turntable is in home position.

The feedback signal of an incremental rotary controller (directly attached to the DC gear motor) is used to determine the exact position of the turntables. The rotary controller generates 2 signal patterns in order to determine both, the rotation direction of the turntable and to measure the turntable's alignment by counting the number of rotation steps.

The microcontroller is programmed to interpret text commands received over a serial interface. Furthermore, status information such as the current alignment can be requested from the microcontroller software. When the WGW is powered up, all turntables are aligned to their home position. During normal operation the microcontroller controls the DC motor and counts the pulses from the rotary encoders until the desired position is reached.

The microcontroller is not aware of cardinal directions. Instead it is only aware of the angular displacement of each turntable compared to its home position. The software accepts additional commands to store the actual turntable positions in a non-volatile memory. This stored position is recovered when the device powers up and the homing procedure is finished. The microcontroller is connected to the prototypes main logic board via serial interface.

The Switch on the base layer also provides power over Ethernet to the Nanostations on the 3 top layers. The microcontroller, the motors and the sensors are power supplied by a 5V DC/DC converter installed at the base layer.

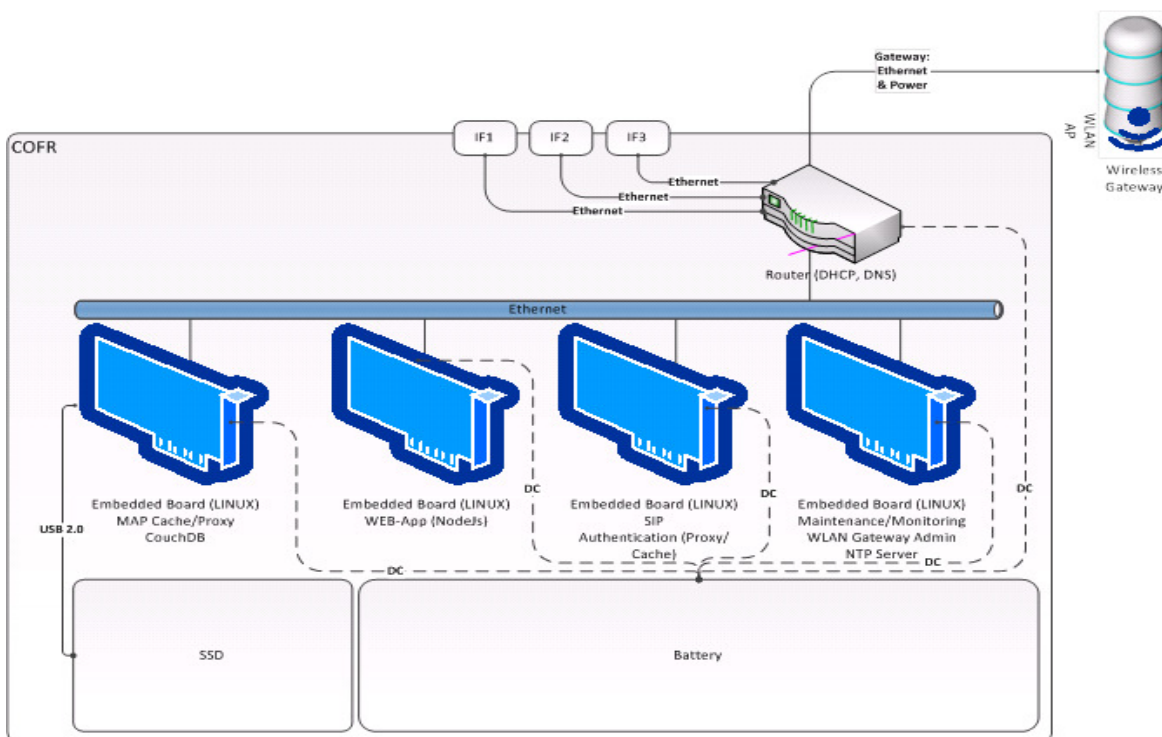

Figure 5: Building blocks of the Communication Field Relay.

The second part belonging to the mobile communication equipment is the so called Communication Field Relay or, for short, COFR. COFR and WGW are intended to be installed as a compound that provides connectivity to the MICS or Fixed Infrastructure for relief workers at any arbitrary location in the disaster area. The Communication Field Relay is positioned at the foot of the pole the WGW is mounted on, and it is connected to the WGW by Ethernet LAN and, thus, connected to the backbone network spanned by the WGWs. A schematic diagram of the COFR is shown in Figure 5.

The COFR is intended to provide several services for the IDIRA communication system. As a local communication hub for field commanders the COFR can provide a SIP service to allow for voice communication between field commanders without the need of a connection to the Fixed Infrastructure or the MICS – this grants more efficient bandwidth usage. Furthermore, the COFR can act as a communication proxy providing capabilities to cache data exchanged between end device applications and the IDIRA disaster information system. This guarantees a seamless operation even in cases the direct data exchange between an end device application and the central information system suffers from limited communication quality. The proxy service may also include a map server supplying geographic data to end devices. This has the advantage that potentially large map data are not needed to be transmitted multiple times for multiple end devices over a potentially constraint wireless backbone connection.

From a networking perspective the COFR offers a DHCP server and DNS server capabilities granting simplified end device configuration. End devices automatically get a valid IP configuration (DNS, IP address, gateway address, etc.) after the device is attached to the network. These services are supplied to devices using the wireless connection to the 802.11 hotspot (spanned by the WGW) or to devices directly wire-connected to the COFR via Ethernet. One Ethernet port of the COFR is especially considered for this case. A second Ethernet port is intended to be used as direct Internet uplink. Any arbitrary Internet uplink technology such as DSL, WiMAX, satellite-communication, UMTS, or LTE can be used. This Internet uplink can be shared by all clients connected to this COFR, to the local WGW or, to any remote COFR or WGW. The route is distributed by the OLSR dynamic gateway plugin. A third Ethernet port is used for the connection to the WGW and is providing - beneath communication capabilities - power supply to the WGW via Power over Ethernet (PoE). Therefore, the COFR can be connected to a power source either by a 230 V power socket or, if a power line or power generator is not available, to a battery via a 12 V cigarette lighter socket.

A COFR is assembled of several embedded Linux boards (Raspberry PI) providing the software services mentioned above. As data storage a fast and energy efficient solid-state disk is included. Furthermore, a router allowing for connecting different hosts via cable and ensuring the connection to the Wireless Gateway (WGW) is part of the system. The router is also responsible for the Internet uplink.

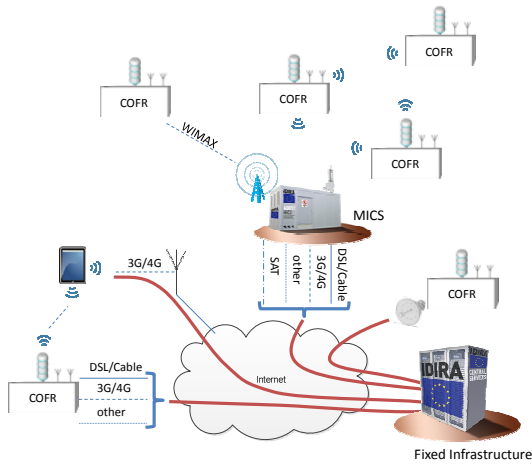

Figure 6: IDIRA communication network.

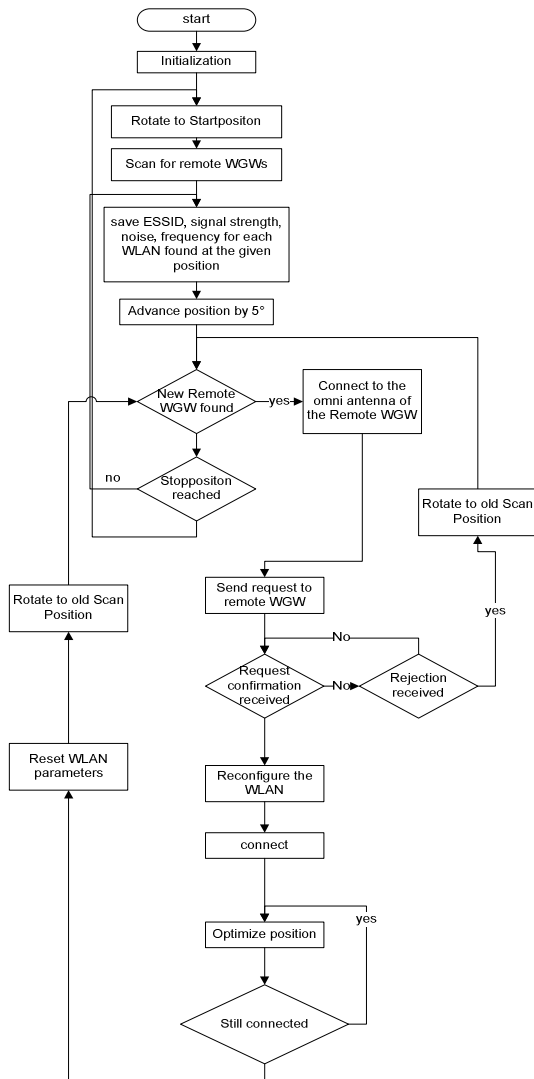

Figure 7: Local Alignment Algorithm

Figure 6 shows a full-featured disaster communication network based on the proposed components. The depicted network consists of the MICS (installed at the Command and Control Center on-site), several mobile communication sites (WGW/COFR) and also the Fixed Infrastructure which is connected over Internet. The figure also shows that WGW/COFR compounds are using a variety of connection methods either to the MICS (via Wireless LAN or WIMAX) or to the Fixed Infrastructure (via various Internet uplink technologies). A fully operational mobile communication node consists of a WGW/COFR compound, a battery pack with capacity for about 12 hours, together with a tripod and a telescopic 6 m pole.

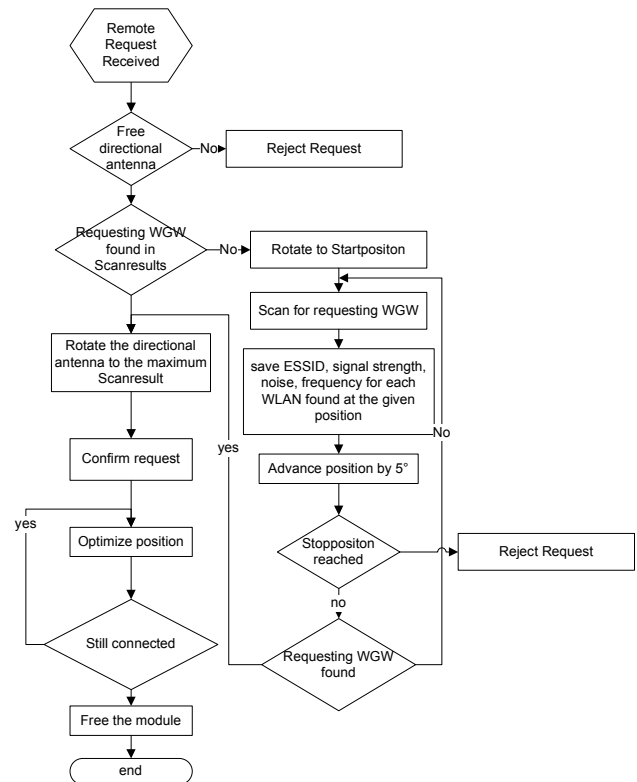

Figure 8: Remote Alignment Algorithm

B. Antenna Alignment and Networking Configuration

After powered on, the WGWs try to connect to remote WGWs following an alignment algorithm. Figure 7 and Figure 8 show a simplified flow-diagram of the alignment algorithm performed by a requesting (local) WGW and a responding (remote) WGW. Figure 9 shows the state diagram the alignment algorithm is based on. The state diagram shows the individual states of each of the three top layers of the WGW. The alignment algorithm is executed on the router-board on the lowest level of the WGW.

After supplying power to the WGW via PoE, the local adjustment sequence (see Figure 7) starts an initialization process. This initialization process identifies the home

positions of the modules and performs a self-check of the system. After the initialization, all three modules start to scan for remote WGW signals radiated by their 5GHz omnidirectional antenna. For each module, individual start and stop positions are defined with an offset of 120° to each other. This allows for scanning the full 360° around the WGWs as fast as possible. During the scanning process, the antenna position is advanced by 5° in each step. One step lasts about 10 seconds, which is mainly determined by the time needed to execute the scan. The scan is stopped as soon as a module reaches its stop position or a remote WGW has been detected. When the stop position has been reached, the antenna is rotated to its starting position and the scanning process is restarted again.

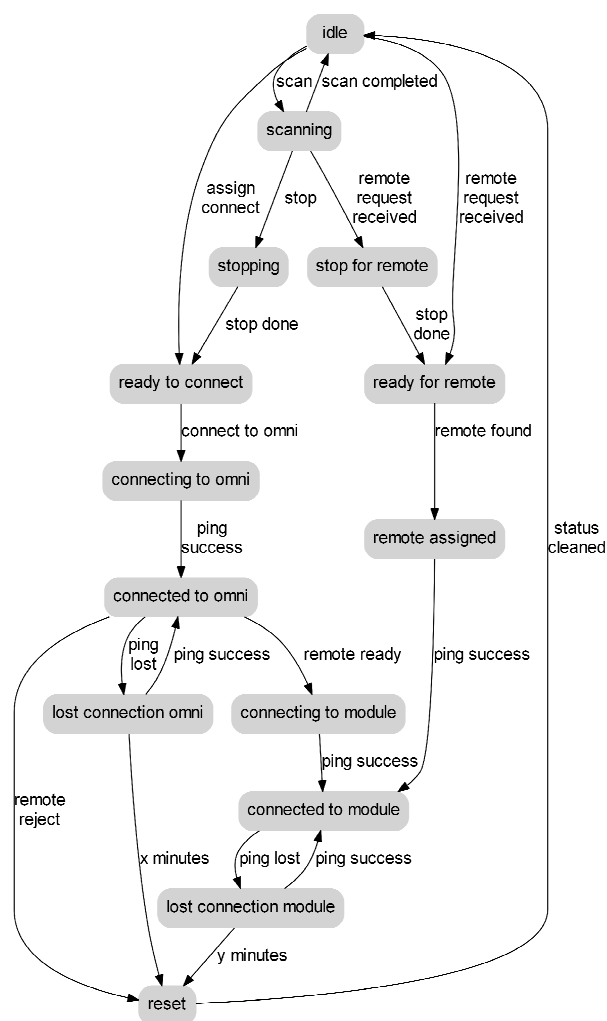

Figure 9: Alignment process state diagram.

In case of the 5GHz remote signal has been detected with signal strength greater than -87 dbm, one directional antenna of the detecting WGW rotates to the position with the best strength of this signal. This antenna may not be the same as the one detecting the signal.

During the scanning phase, the Nanostations M5 are configured to operate in access point (AP) mode as the firmware of the M5 only allows in AP mode to execute distinct scans for each scanning position. In station mode, in contrast, scan results are cached by the firmware over several scans. This, however, would make it impossible to map certain scan results to distinct positions.

After the module has reached the best known position for this signal, the module is configured in station mode to connect to the omnidirectional antenna of the remote WGW. As IP based communication is needed for the following steps, also the IP configuration of the local WGW is done such that the local module configures itself with an IP address of the remote WGW. As for performance constraints no DHCP server is running at the remote WGW and a distinct mapping of IP addresses to WLAN SSIDs is used. Each WLAN spanned by the omnidirectional antenna of the WGWs is sending a distinct SSID. Based on this SSID, the alignment and configuration algorithm knows the IP address a connecting module needs to build up an IP based connection. An example for a connection to an omnidirectional antenna is shown in Figure 10. After a connection is established and the corresponding IP configuration is done, the local WGW sends a request to connect to a directional antenna at the remote WGW.

At this time, the local WGW and the remote WGW are following distinct algorithm steps to establish the directional point-to-point connection. While the connecting WGW is following the remaining steps shown in Figure 7 (starting with checking if a request confirmation was received), the remote WGW will follow the sequence shown in Figure 8, as soon as a request has been received.

When a connection request is received, one module is determined for the directional connection. If no module is available (because all are used for other connections) a reject is sent to the requesting WGW. Otherwise, the scan results will be searched for results of the requesting WGW. If such a result exists the determined module is rotated to the corresponding position with the best signal strength and a confirmation is sent to the requesting WGW. If such a scan result cannot be found, all available modules starting a 360° full scan beginning from their start positions. This scan is executed until the requesting WGW is found or the stop position is reached. If the signal of the requesting WGW has been found, a confirmation is sent and a module is rotated to the position with the best signal strength known. Otherwise, the request is rejected.

When the requesting node receives the confirmation the connection to the remote WGW omnidirectional antenna is canceled, and the local WGW is configured to connect to the remote directional module. The local module is configured in station mode with the SSID of the remote module and the IP address is set according to the SSID of the remote module using a similar approach as when connecting to the omnidirectional antenna. Furthermore, also the IP address is set appropriately for the remote module (see Figure 10). If the request is rejected the module will continue scanning for remote WGWs.

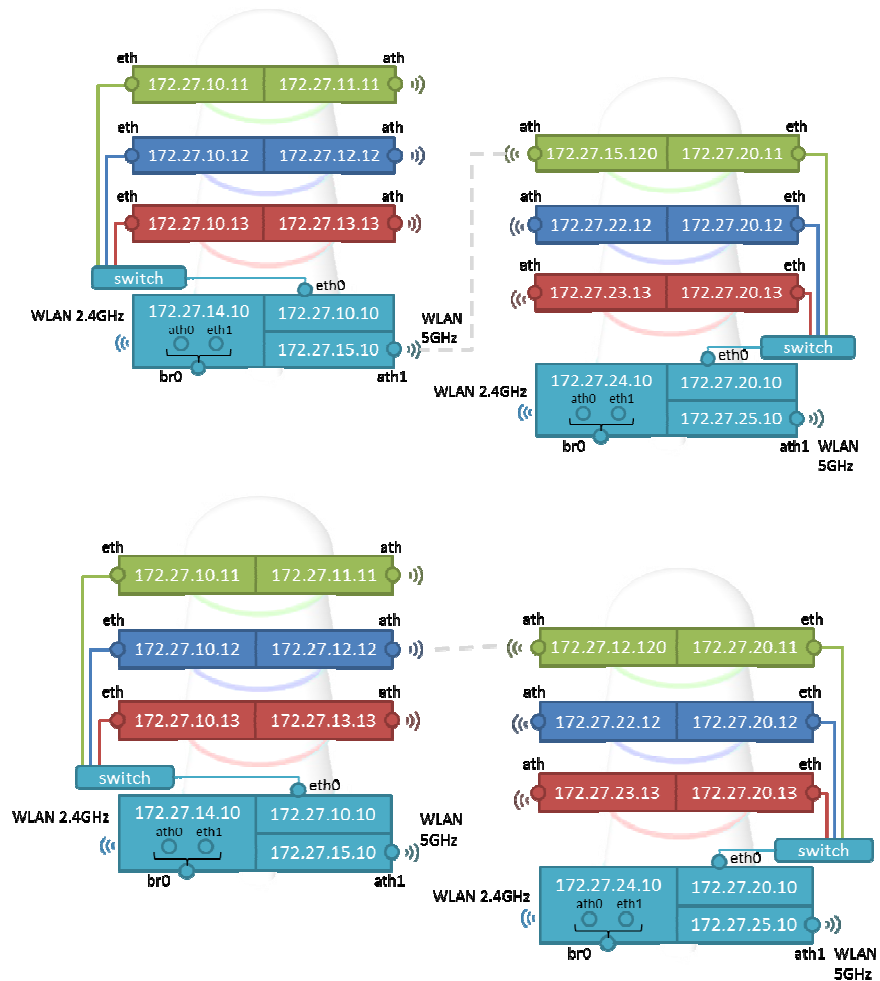

Figure 10: IP addressing scheme when connected to the omnidirectional antenna (above) and after successful connection between two WGW devices (below).

The alignment sequence typically lasts between five and 15 minutes. All established connections are monitored, and if one of them is lost the module will be reconfigured and starts to scan for remote WGWs again or connect to another previously located WGW. Not connected modules will continue to scan for remote WGWs. New scan results (coming from modules in scanning state) are used to adjust the position to ensure the best possible position to the remote WGWs based on the signal strength.

Another view on the alignment procedure can be given by the state diagram shown in Figure 9. This diagram shows the states of each module and all transitions between them. State transitions are executed by a central control instance separately for each module.

After powering up and during node initialization, the modules are in idle state. From the idle state, the control instance may trigger to perform a scan, trigger to connect to a remote WGW if a remote WGW is already known or being ready to be assigned to a remote WGW if a connection request is received from a remote WGW.

When a module completes a scan (after reaching the end position) it returns into the idle state and is realigned and triggered to start another scan. If a remote WGW is identified, the control instance chooses one scanning or idle module that should connect to the remote node and switches it to state “ready to connect”.

If a remote request is received, the control instance also chooses one scanning or idle module that is then used for establishing the directed point-to-point connection. The module is switched in state “ready for remote”. If the requesting WGW has been identified the module is rotated towards the remote node position and its state is changed to “remote assigned”.

Once the connection is established, the module’s state is changed to “connected to module” and this connection is regularly checked. If the connection is lost it will change the state to “lost connection module” and try to re-establish the connection for y minutes. If it fails to re-establish the connection, it will change the state to “reset” and finally to “idle”.

If a remote WGW has been identified in “scanning” state without receiving a request from it (i.e., the local WGW found the remote WGW first), one available local module will be reconfigured with an appropriate IP address to be able to connect to the 5GHz omni-directional antenna of the remote WGW. Also, the module is set to state “connected to omni” and the remote WGW is informed about the attempt to establish a point-to-point connection. If the connection to the remote WGW is lost, it is tried to re-establish the connection for x minutes, afterwards it will change the state to “reset” and finally to idle after all specific settings are reset. In case that the remote WGW node answers the request in a positive manner, the module is reconfigured and a connection to the remote module will be established.

C. Node Positioning Support

To install a field communication site is easy as it only requires mounting the WGW on a pole and connecting it to a COFR and a power source. But before a communication site can be established, one important question needs to be answered: Which location is particularly appropriate to setup a communication site where a WGW provide WLAN coverage for relief forces and is able to build up a backbone connection to other remote WGWs.

This section describes the Reachability Optimized Positioning (ROP) application of IDIRA. ROP provides a Web based interface, which is fully integrated into COP and helps to find the best possible locations for setting up communication sites. Commanding personnel can run WLAN coverage simulations at arbitrary locations on the COP map in order to evaluate the WLAN coverage at this place regarding to range and signal quality of the directional antennas. This information is then used by early responder teams to identify the optimal location for a communication site where a direct line of sight is available between multiple WGWs.

ROP calculates the radio signal propagation based on a digital earth surface model of the operational area. For this purpose, an extension of the open source tool SPLAT! [24] version 1.4 was developed, which uses a surface model with a resolution of $1/10^{\text{th}}$ of an arc second. SPLAT! provides radio signal propagation based on a terrain analysis for the electromagnetic spectrum between 20 MHz and 20 GHz. The calculations are based on the Longley-Rice Irregular Terrain [25] as well as the new Irregular Terrain with Obstructions (ITWOM v3.0) [26] model. In its base version SPLAT! uses the elevation data from the U.S. Geological Survey and Space Shuttle Radar Topography Mission [27]. These data have a resolution of 1 arc second for some areas of the Earth's surface and 3 arc seconds for the remaining areas.

To achieve precise results in a radio wave propagation simulation this resolution is too coarse grained. To solve this issue an Earth surface data basis with a high resolution of $1/10^{\text{th}}$ of the Earth surface was chosen, which is available from some satellite remote sensing programs such as TerraSAR-X [28] or from local authorities for some specific regions. This is where an extension of SPLAT! was necessary, as higher resolved Earth surface data are not supported by SPLAT!. To make highly resolved elevation

data usable in SPLAT!, the application had to be extended in order to allow SPLAT! to read, use and visualize this kind of elevation and surface data and also the algorithm to compute radio wave propagation was slightly adapted to the new data basis. With the increased resolution to $1/10^{\text{th}}$ of an arc second the distance between points with available elevation data is approximately 3 m (for central Europe). This gives sufficient accurate propagation models to have guaranteed communication channels between WGWs. The coverage simulation also considers the operating height of the WGW of about 6 m and the results show if it is possible to establish line of sight communication between two WGWs absent of obstructions due to buildings, hills, or forests.

To find the appropriate places and areas, the commanding staff starts a signal propagation simulation with a pole at the location of the MICS. The result of the calculation is a picture of the signal propagation simulation shown in Figure 11 as an overlay of the COP map.

The white section in the circle indicates an area where it is possible to deploy the wireless gateways and to establish a communication channel to remote WGWs automatically. The red or dark grey area indicates that it is not possible to establish a communication infrastructure due to obstacles between the directional antennas. In the middle of the circle, the green or light grey area gives the commander the information that it is possible to support mobile equipment for communication in the incident area. These simulation results are presented within COP together with incident locations. Consequently, within one system tactical needs as well as communication needs can be taken into account when decisions for operational locations in the field of first responder field commanders have to be defined.

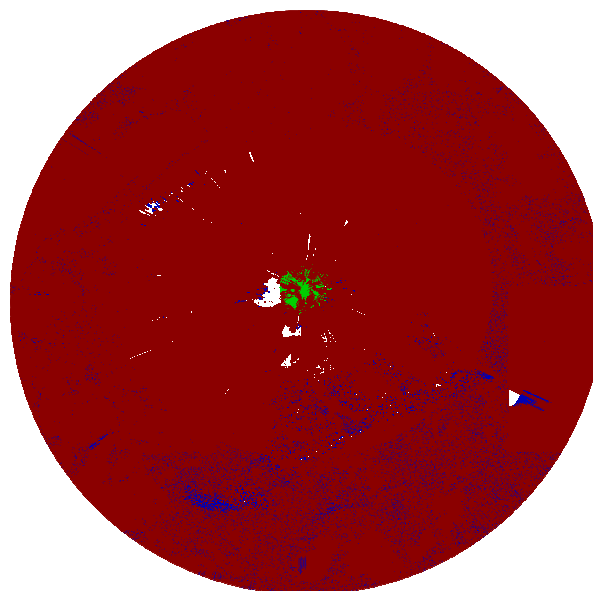

Figure 11: Result of a radio signal propagation simulation.

ROPs usability and correct way of working were proven in a validation test before it was used in multiple field trials

of the IDIRA communication system. The result of the validation test is shown in Figure 12.

Based on a simulation of the base area where the command and control center was located, ten places were defined to validate the possibility to establish a communication channel fully automatically (Point 1 - Point 10).

After the wireless gateways were deployed to the different places it was evaluated if a communication channel could be automatically established by the alignment algorithm:

- Wireless gateways placed on areas indicating a good signal to noise ratio (green and yellow, respectively light grey areas), could successfully setup a communication channel: Yellow pins (Points 2, 4, 5, 9, and 10).
- Wireless gateways placed in red or dark grey areas failed to setup a communication channel automatically: Red pins (Points 1, 3, 6, 7, and 8).

These results show that the accuracy of the radio signal propagation simulation was sufficient to give a reliable answer to the question where communication sites should be established in order to build a backbone network allowing for a connection to the IDIRA information system.

More detailed performance evaluation results of the IDIRA communication system can be found in [1][29][30][31]. These papers contain results of several performance tests, end user training events, and large scale exercises held in context of the IDIRA project.

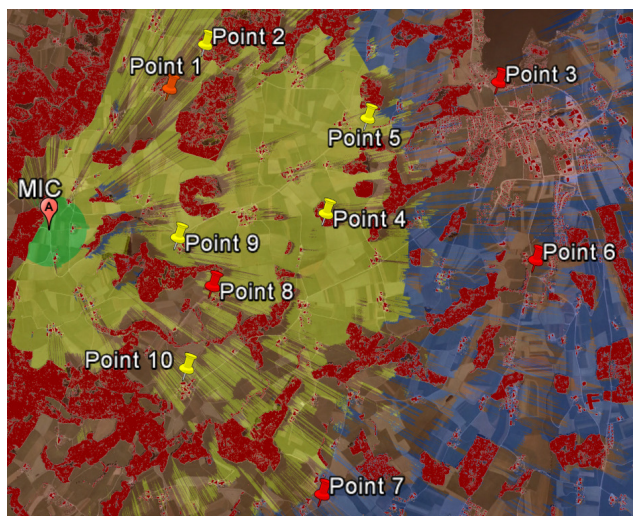

Figure 12: Simulation validation.

V. CONCLUSION AND FUTURE WORK

This paper presents the information and communication systems developed within the EU funded project IDIRA. The main goal of IDIRA was to develop a solution to enhance interoperability and cooperation of relief units part of multinational disaster response organizations working together after a large scale disaster. Such a solution considers two aspects of interoperability. Organizational aspects

dealing with the administrative coordination of various disaster relief organizations, and technical aspects to find technological solutions to enhance information interchange.

This paper focuses on the latter and presents various applications referred to as the IDIRA information system, which can help to find right decisions quickly and provide a common sight on what is happening within the disaster relief action. Furthermore, and with even more focus on details, a mobile communication system is presented providing wireless communication at almost any location within the disaster area.

This communication system complies with several requirements that have been introduced by action forces of relief organizations, such as easy installation and transportation, interoperability with existing communication systems and, international operation permission. The core of this system is the WGW/COFR compound to be installed out in the field of a disaster area granting wireless communication capabilities to field personnel. The field personnel is able to access the central information system of IDIRA. To allow this, in the background the WGW establishes a wireless connection to the central information system potentially using multiple other WGWs as wireless communication hops. The COFR provides power supply and Internet uplink to the compound. An additional application was developed helping first responders to setup the WGW/COFR compound at the right location, where it is possible to build up a wireless backbone network and supply an area near an operation site with a 802.11 wireless hotspot.

In several large scale exercises and user training events the usability of the IDIRA system has been proven. In these events, however, it was shown that several enhancements could improve the systems performance and should be considered in future. (1) Especially the WGWs mechanics should be built in a more robust way in order to make the system more capable for conditions in disaster operations. (2) The extension of the alignment algorithm with manual provided additional information could speed up the automatic alignment process. (3) Additional software interfaces to further existing disaster management tools and a broader variety of sensor sources will be provided.

ACKNOWLEDGMENT

This work was partially supported by the IDIRA European FP7 261726 research project.

REFERENCES

- [1] Peter Dorfinger, Ferdinand von Tüllenbug, Georg Panholzer, and Thomas Pfeiffenberger, "A Flexible Self-Aligning Communication Solution for Multinational Large Scale Disaster Operations," Proc. of the ICN 2015: The Fourteenth International Conference on Networks (ICN2015), April 19 - 24, 2015 - Barcelona, Spain, pp. 230-236.
- [2] Nalini Suparamaniam and Sidney Dekker, "Paradoxes of power: the separation of knowledge and authority in international disaster relief work," Disaster Prevention and Management, vol. 12, no. 4, pp. 312-318, 2003.

- [3] IDIRA Project. *Interoperability of data and procedures in large-scale multinational disaster response actions, 2011-2015* [Online]. Available from: <http://idira.eu/>. 2015.11.30.
- [4] OASIS Emergency Management TC. *Emergency Data Exchange Language (EDXL)* [Online]. Available from: https://www.oasis-open.org/committees/tc_home.php?wg_abbrev=emergency 2015.11.30.
- [5] OASIS Emergency Management TC. *Common Alerting Protocol Version 1.2, 2010-07-01 - CAP-v1.2-os* [Online]. Available from: <https://www.oasis-open.org/standards#capv1.2> 2015.11.30.
- [6] OASIS Emergency Management TC. *Emergency Data Exchange Language Resource Messaging, EDXL-RM-v1.0-OS-errata-os, 22 Dec. 2009* [Online]. Available from: <https://www.oasis-open.org/standards#edxlrn-v1.0> 2015.11.30.
- [7] OASIS Emergency Management TC. *Emergency Data Exchange Language Situation Reporting, edxl-sitrep-v1.0-wd19, Draft 02, 2012-08-07* [Online]. Available from: <http://docs.oasis-open.org/emergency/edxl-sitrep/v1.0/cs01/edxl-sitrep-v1.0-cs01.zip> 2015.11.30.
- [8] ETSI TR 103 269-1. *TETRA and Critical Communications Evolution (TCCE); Critical Communications Architecture; Part 1: Critical Communications Architecture Reference Model* [Online]. Available from: http://www.etsi.org/deliver/etsi_tr/103200_103299/10326901/01.01.01_60/tr_10326901v010101p.pdf 2015.09.14.
- [9] Inmarsat BGAN. *Broadband Global Area Network* [Online]. Available from: <http://www.inmarsat.com/service/bgan/> 2015.11.30.
- [10] GVF VSAT. *Global Very Small Aperture Terminal Forum* [Online]. Available from: <http://www.gvf.org> 2015.09.14.
- [11] Emergency.lu. [Online]. Available from: <http://www.emergency.lu> 2015.09.14.
- [12] IEEE 802.16 WIMAX. *IEEE Standard for Local and metropolitan area networks* [Online]. Available from: <http://standards.ieee.org/about/get/802/802.16.html> 2015.11.30.
- [13] IABG mbH. *HiMoNN Higly Mobile Network Node* [Online]. Available from: <http://www.himonn.de> 2015.08.31.
- [14] Electronic Communications Committee (ECC). *The Identification of Frequency Bands for the Implementation of Broad Band Disaster Relief (BBDR) Radio Applications in the 5 GHz Frequency Range* [Online]. Available from: <http://www.erodocdb.dk/docs/doc98/official/pdf/REC0804.pdf> 2015.11.30.
- [15] Christian Raffelsberger and Hermann Hellwagner, "Evaluation of MANET Routing Protocols in a Realistic Emergency Response Scenario," Proc. of the 10th Workshop of Intelligent Solutions in Embedded Systems (WISES'12), July 2012, pp. 88-92.
- [16] Matthias Herlich and Shigeki Yamada. "Motivation for a Step-by-Step Guide to Set up Wireless Disaster Recovery Networks," Proc. of the International Conference on Information and Communication Technologies for Disaster Management (ICT-DM 2015).
- [17] IEEE 802.11. *IEEE Standard for Information Technology--Telecommunications and Information Exchange Between Systems--Local and Metropolitan Area Networks--Specific Requirements Part 11: Wireless LAN Medium Access Control (MAC) and Physical Layer (PHY)* [Online]. Available from: <http://standards.ieee.org/about/get/802/802.11.html> 2015.11.30.
- [18] Thomas Clausen and Philippe Jacquet. (2003), "Optimized Link State Routing Protocol (OLSR)," Internet Engineering Task Force, IETF, RFC 3626.
- [19] Harald Rieser, Peter Dorfinger, Vangelis Nomikos, and Vassilis Papataxiarhis, "Sensor Interoperability for Disaster Management," Proc. of the Sensor Applications Symposium (SAS2015) Zadar, Croatia; April 2015, pp. 389-395.
- [20] Satways, OptiFire [Online]. Available from: http://www.satways.net/index.php?option=com_content&view=article&id=95:optifire-article&catid=53:simulation-a-modelling&Itemid=91&lang= 2015.11.30.
- [21] Kostas Kolomvatsos, Kikia Panagidi, and Stathes Hadjiefthymiades, "Optimal Spatial Partitioning for Resource Allocation," Proc. of the 10th Int. ISCRAM Conference. May 2013.
- [22] Ubiquiti networks. *NanostationM & NanostationlocoM Datasheets* [Online]. Available from: http://dl.ubnt.com/datasheets/nanostationm/nsm_ds_web.pdf 2015.11.30.
- [23] David Gesbert and Jabran Akhtar, "Breaking the barriers of Shannon's capacity: An overview of MIMO wireless systems", Telenor's Journal: Elektronik, vol. 98, no 1, pp. 53-64, 2002.
- [24] John A. Magliacane. (2002) Splat! [Online]. Available from: <http://www.qsl.net/kd2bd/splat.html> 2015.11.30.
- [25] Anita Longley and Phill Rice, "Irregular terrain model," Institute for Telecommunication Sciences, 1968.
- [26] Georgelpon Hufford, "The its irregular terrain model, ver 1.2.2," National Telecommunications and Information Administration.
- [27] U.s. geological survey. U.S. Geological Survey. [Online]. Available from: <http://srtm.usgs.gov/> 2015.08.31..
- [28] Airbus Defence & Space. TerraSAR-X Radar Satellite Imagery. [Online]. Available from: <http://www.geo-airbusds.com/terrasar-x/> 2015.11.30.
- [29] Thomas Pfeiffenberger, Peter Dorfinger, and Ferdinand von Tullenburg "Communication Coverage Awareness for Self-aligning Wireless Communication in Disaster Operations," Pervasive Networks for Emergency Management March 2015 St. Louis, Missouri, USA.
- [30] Peter Dorfinger, Ferdinand von Tullenburg, Georg Panholzer, Massimo Cristaldi, Giovanni Tusa, and Franz Böhm "An Offline Capable Communication Framework for Multinational Disaster Operations based on Self-aligning Wireless Gateways," Proceedings of International Conference on Digital Information Processing, Data Mining, and Wireless Communications (DIPDMWC2015) Dubai, UAE January 2015.
- [31] Peter Dorfinger, Georg Panholzer, Ferdinand von Tullenburg, Massimo Christaldi, Giovanni Tusa, and Franz Böhm "Self-aligning Wireless Communication for First Responder Organizations in Interoperable Emergency Scenarios," In: Proc. of the 2014 International Conference on Wireless Networks, Las Vegas Nevada, USA.